

# AGENDA

This meeting will include the boards of Sheridan Fire District, SW Polk Fire District and West Valley Fire District

Joint Regular Board Meeting  
Sheridan Fire District  
230 SW Mill St.  
Sheridan, OR 97378

February 13, 2020 at 6:00 pm

1. Call Meeting to Order
2. Pledge of Allegiance
3. Roll Call
4. Approval of Minutes/All Agencies
5. Financial Report
  - A. Sheridan
  - B. SW Polk
  - C. West Valley
6. Audience Participation
7. Old Business
  - A. 2018-2019 Audit.....SFD.....Discussion
    - i. Please bring your audit copies from last month
  - B. Fire & EMS Coalition.....ALL.....Discussion
  - C. General Operating Levy.....WVFD.....Discussion/Action
    - i. Minutes
    - ii. Resolution 19-20-3 draft (working with SDAO for final draft to be distributed at meeting)
  - D. Fire Authority Model.....ALL.....Discussion/Action
  - E. SDAO Conference.....ALL.....Discussion
  - F. Invitation to Bid Draft.....SW Polk.....Discussion/Action
8. New Business
  - A. Apparatus Replacement Presentation.....ALL.....Discussion
  - B. Apparatus Surplus Recommendations.....ALL.....Discussion/Action
  - C. Student Resident Volunteer Program.....ALL.....Discussion
  - D. Appoint 2020-2021 Budget Officer.....SFD/SW Polk/WVFD.....Discussion/Action
  - E. Appoint 2020-2021 Budget Committee Members.....ALL.....Discussion/Action
9. Chief's Report
10. Director comments and/or agenda items for next month
11. EXECUTIVE SESSION authorized under ORS 192.660(2)(i) to review and evaluate the performance of an officer, employee or staff member if person.
12. Adjournment
  - a. Next meeting March 12, 2020 at SW Polk, Rickreall Station

Oversight Committee Meeting  
February 3<sup>rd</sup>, 2020  
West Valley Fire Station  
825 NE Main St. Willamina, OR 97396

1. Reviewed combined Fire Chief's Performance Review form
2. Discussed budget committees. There was a request to complete a three-year projection for where the three districts would be if they West Valley levy does not pass compared to if it does pass.
3. Discussed the protentional levy for West Valley. Reviewed the importance of the levy and its impact on the community if it does not pass. "The destiny of the ambulance service is in your hands" was mentioned as a slogan for the levy since the levy is focused on the EMS services.
4. Discussed the continuation of the Fire and EMS Coalition. Polk County No. 1 took the request to join the coalition to their board and the board voted against joining. Falls City has requested that the administration for Sheridan, SW Polk and West Valley take over Falls City administration. This change could go into effect as early as July 2020.

**Sheridan/SW Polk/West Valley Fire Districts  
Joint Regular Board Meeting  
825 NE Main St. Willamina, OR 97396  
January 9, 2020 – 6:00 p.m.**

**ROLL CALL**

Fred Hertel – SFD/SW Polk/WVFD Fire Chief  
Damon Schulze – SFD/SW Polk/WVFD Deputy Chief

**Sheridan Fire District**

Scot Breeden  
Tammy Heidt  
Dennis Grauer (Absent)  
Brice Ingram  
Dennis Rogers

**SW Polk Fire District**

Rod Watson  
Bob Davis  
Keith Moore  
Frank Pender  
Bruce Sigloh

**West Valley Fire District**

Chirs Greenhill  
Rick Mishler  
Gary Brooks  
Don Shelton  
Roy Whitman (Absent)

**Audience**

Damon Schulze  
Les Thomas  
Jason Crowe  
Judy Breeden  
Brad Weaver  
Todd Brumfield  
Ken Waller  
Jake Rosenbalm  
Eric Hines

**President Chris Greenhill, West Valley Fire District, opened the meeting at 6:05 pm.**  
Each agency has a quorum of directors and will allow deliberation, decision making and will take public comment per the posted agenda.

**FLAG SALUTE**

**Approval of Minutes - All agencies**

**Sheridan/SW Polk/West Valley Fire Districts  
Joint Regular Board Meeting  
825 NE Main St. Willamina, OR 97396  
January 9, 2020 – 6:00 p.m.**

Corrections needed: Page 4- December 8<sup>th</sup> needs changed to 18<sup>th</sup>  
Page 6- incomplete sentence, add “safe and healthy”

**SFD/SW Polk/WVFD**

**Motion: Dennis Rogers**

**Second: Rick Mishler**

**Move to approve the minutes from the joint board meeting with the above corrections made. Motion passed.**

**SFD: Heidt; aye Breeden; aye Rogers; aye Grauer; absent Ingram; aye**

**SW Polk: Watson; aye Davis; aye Pender; aye Moore; aye Sigloh; aye**

**WVFD: Brooks; aye Greenhill; aye Mishler; aye Shelton; aye Whitman; absent**

**Financial Report – All agencies**

**SFD**

**Motion: Tammy Heidt**

**Second: Dennis Rogers**

**Move to approve the financial report as written. Motion passed.**

**Discussion:** Judy Breeden provides an additional report that is up to date through the end of January, which includes the contractual deposits. The total to Sheridan will be 56% of the budgeted total for the contractual agreement between Sheridan, SW Polk and West Valley.

**Heidt; aye Breeden; aye Rogers; aye Grauer; absent Ingram; aye**

**SW Polk**

**Motion: Frank Pender**

**Second: Bruce Sigloh**

**Move to approve the financial report as written. Motion passed.**

**Discussion:** Clarification on which LGIP the \$50,000 went and which LGIP it came from. The money will come from the Contingency and be transferred to the General Fund. Clarification was asked what the check to Brad Weaver was for and what the WireWorks bill for apparatus replacement was for. The check to Brad Weaver was for the parking event at the Polk County fairgrounds. It was written out of the volunteer account, not the operating account. The WireWorks payment is for the new S1901 vehicle for lights, communications, etc. Judy Breeden provides an additional report that is up to date through the end of January, which includes the contractual deposits. The total to Sheridan will be 52.5% of the budgeted total for the contractual agreement between Sheridan, SW Polk and West Valley.

**Watson; aye Davis; aye Pender; aye Moore; aye Sigloh; aye**

**WVFD**

**Motion: Rick Mishler**

**Second: Don Shelton**

**Move to approve the financial report as written. Motion passed.**

**Discussion:** Clarification on what the IRS withdraw was for. It was for payroll taxes.

Clarification was requested for what the MES bill was for. It was clarified that was \$2000 to match the grant money to gain wildland PPE. The question was posed about how much longer Acuity will be paid. Judy Breeden has a meeting with Acuity next week, so there will be more answers soon. The professional fees are significantly over budget. This is due, in part, for the

**Sheridan/SW Polk/West Valley Fire Districts  
Joint Regular Board Meeting  
825 NE Main St. Willamina, OR 97396  
January 9, 2020 – 6:00 p.m.**

audit which came \$10,000 over what was budgeted, the feasibility study, and the CRDI report. The question was posed about who will be doing the West Valley Audit. Penny Rogers will be completing the audit. There was question as to what the \$102,000 for payroll expenses was for. This was for PERS, at it needed caught up due to Acuity being behind. The Casino contract is set to at \$550,000, which is not the EMS and fire services contract alone. It was clarified that this line item is the Casino contract and the Confederated Tribes of Grand Ronde combined. The net income line appeared skewed. Judy Breeden provides an additional report that is up to date through the end of January, which includes the contractual deposits. The total to Sheridan will be 55% of the budgeted total for the contractual agreement between Sheridan, SW Polk and West Valley.

**Discussion: Brooks; aye Greenhill; aye Mishler; aye Shelton; aye Whitman; absent**

It was asked if the interest from the money owed to Sheridan from the past six month will be paid back. Calculations will be brought to the next board meeting.

**AUDIENCE PARTICIPATION- None**

**OLD BUSINESS**

**Fire & EMS Coalition – All**

An update was given that Chief Hertel is attempting to bring in more agencies to the coalition.

**General Operating Levy – WVFD**

Concern was expressed that the “Volunteer Board of Directors” implies volunteering is all that is required. “Elected Board of Directors” was given as an alternative. “Board of Directors” with “Publicly elected board of unpaid directors.” as the description.

Corrections needing to be made: Skyberg Lumber and date needs changed to Jan 6, 2020.

**Motion: Gary Brooks      Second: Don Shelton  
Move to approve the workshop minutes as written. Motion passed.  
Brooks; aye Greenhill; aye Mishler; aye Shelton; aye Whitman; absent**

**Fire Authority Model – All**

Discussion was tabled until a later date.

**Budget Resolution for S1901- SW Polk**

**Motion: Frank Pender Second: Bruce Sigloh  
Move to approve Resolution 2019-03 as written. Motion passed.  
Discussion:**

**Sheridan/SW Polk/West Valley Fire Districts  
Joint Regular Board Meeting  
825 NE Main St. Willamina, OR 97396  
January 9, 2020 – 6:00 p.m.**

**Watson; aye Davis; aye Pender; aye Moore; aye Sigloh; aye**

**SDAO 2020 Conference – ALL**

Clarification given on who is attending as listed on the agenda.

**NEW BUSINESS**

**Resignation of Director Dennis Grauer**

President announced Director Dennis Grauer has submitted his resignation. President Breeden requested that the position is open on the website and in the local papers.

**Motion: Tammy Heidt Second: Dennis Rogers**

**Motion to accept the resignation. Motion Passed.**

**Heidt; aye Breeden; aye Rogers; aye Grauer; absent Ingram; aye**

**Motion: Brice Ingram Second: Dennis Rogers**

**Motion to advertise the available position for 60 days. Motion passed.**

**Discussion:** It was asked if it would be beneficial to wait until after this year's election, to prevent the person to have to run multiple times this year.

**Heidt; aye Breeden; aye Rogers; aye Ingram; aye Vacant**

**Invitation to Bid Draft- SW Polk**

A draft was given in the board packet to review and give feedback. The final version could be voted on by the Board at the next Board Meeting. That would allow the bid to go out in February, bids would close in March and construction could begin in April. It was asked how bids could be given on the Bridgeport property if the sale has not closed. It was clarified that the sale will be closed before the Invitation to Bid is approved by the Board.

**Apparatus Purchase- SFD and SW Polk**

Reports were given to the Boards about the recommendations on apparatus purchasing from the Apparatus Committee. It was asked if there are people available to drive the bigger trucks. There are staff and volunteers trained and others willing to learn. The question was posed how the district plans to handle the insurance recommending that tenders be driven code 1 (no lights and sirens) to a scene. It was clarified that if the tender is driven either full or empty, the stabilization is safer than if it was half full. Specifications for the apparatus were requested. Length will be about one foot longer than current first out engines, about the same height, and will hold 2,000 gallons. The pump will be a different style than currently used, which allows for a shorter engine. There are other agencies in the state that are happy with the apparatus. Up until the time that the apparatus are put into production (several months from the purchase date) changes can be made to the specifications of the apparatus. That allows for time for changes if the bid for construction for the stations come in differently than planned. Sheridan passed a levy in May 2017 that lists a replacement engine as part of where the money would go. The question was posed if the medic would be a better use of the money, however the public was promised

**Sheridan/SW Polk/West Valley Fire Districts  
Joint Regular Board Meeting  
825 NE Main St. Willamina, OR 97396  
January 9, 2020 – 6:00 p.m.**

an engine with the levy. The recommended apparatus could replace a pumper and a tender, which would reduce maintenance cost. Delivery for all apparatus is expected around mid-September.

**SFD**

**Motion: Dennis Rogers Second: Tammy Heidt**

**Motion to approve the purchase of apparatus as recommended. Motion Passed.**

**Discussion:** If the need arises to move the pumper tender quickly, there is a dump option, which would allow the water to be dumped and the apparatus could increase their response level. There is also double the amount of water, compared to a typical tender. This new pumper/tender is also easier to drive than the current tender for Sheridan due to the improved brakes and the automatic transmission. If this apparatus is purchased, the medic could be replaced down the road, potentially in two or three years.

**Heidt; aye Breeden; nay Rogers; aye Ingram; aye Vacant**

**SW Polk**

**Motion: Bob Davis Second: Frank Pender**

**Move to approve the purchase of apparatus as recommended, 3 pumper/tenders and 2 wildland vehicles. Motion passed.**

**Watson; aye Davis; aye Pender; aye Moore; aye Sigloh; aye**

**2018-2019 Audit- Sheridan Fire District**

The audit was given to the Board to review. The auditor will be presenting in the February.

**Chiefs Report**

**Chief Weaver SW Polk report**

Report on calls was given to the Boards. Chief Weaver expressed appreciation for the approval of the apparatus purchases.

**Fred Hertel, Fire Chief**

Written Chief's report was reviewed. SDAO grants were awarded to all three districts recently for station security improvements. A Ford Family Foundation grant is being applied for the community room in the new Station 140. SDAO Intern Grant has been applied for. Additional grant deadlines are coming up quickly. The recommendation was given to change the Board Meeting to allow board packets to be out farther ahead of the meeting and there could be exchange of attendance the Polk Co. 1's Board Meetings. Concern was expressed that if the meeting was moved to later in the month, the checks would need to be signed before the Board approves the financials or the bills would be paid after the due date. Discussion was tabled until next month.

**Sheridan/SW Polk/West Valley Fire Districts  
Joint Regular Board Meeting  
825 NE Main St. Willamina, OR 97396  
January 9, 2020 – 6:00 p.m.**

**DIRECTORS COMMENTS AND/OR AGENDA ITEMS FOR NEXT MONTH**

The total donated amount from FCI was \$2,500 for the giving trees that Sheridan and West Valley spent on behalf of FCI inmates.

There are updates being done to Station 197 to make it a better hub for all three districts.

“A leader that has no followers is just out for a walk.”

Thanks were expressed for getting the Christmas Lights up and down.

Reminders were given to get the Chief’s Review to the Mariah Prescott before the next Oversight Meeting. Oversight Committee meeting was scheduled for January 14, 2020 at 5 PM.

Charts for call types for all agencies, similar to the one that is from SW Polk’s Chief Weaver, was requested.

**Next Meeting; February 13, 2019 at 6 pm at Sheridan Fire District.**

**Meeting adjourned at 8:30 pm.**

**Motion: Scot Breeden Second: Bob Davis**

**SFD: Heidt; aye Breeden; aye Rogers; aye Ingram; aye Vacant**

**SW Polk: Watson; aye Davis; aye Pender; aye Moore; aye Sigloh; aye**

**WVFD: Brooks; aye Greenhill; aye Mishler; aye Shelton; aye Whitman; absent**

Respectfully submitted,

Mariah Prescott



### Sheridan Fire District 2018 ANNUAL COLLECTION STATISTICS

Month	Charges	Payments	% Payments	(Levy)	% Disallowed	% Uncollected	% Refunds	% Pending					
January	\$168,708.06	\$60,489.95	36%	\$0.00	0%	\$102,187.57	61%	\$2,523.10	1%	\$0.00	0.00	\$3,507.44	2%
February	\$121,519.88	\$46,250.22	38%	\$0.00	0%	\$72,455.81	60%	\$2,435.42	2%	\$0.00	0.00	\$378.43	0%
March	\$115,346.90	\$40,363.89	35%	\$0.00	0%	\$71,990.29	62%	\$1,128.98	1%	\$0.00	0.00	\$1,863.74	2%
April	\$126,974.96	\$61,793.90	49%	\$0.00	0%	\$63,233.26	50%	\$2,057.70	2%	\$493.37	0.39	\$383.47	0%
May	\$143,334.76	\$58,207.83	41%	\$0.00	0%	\$81,226.81	57%	\$2,250.52	2%	\$0.00	0.00	\$1,649.60	1%
June	\$138,276.54	\$55,236.23	40%	\$0.00	0%	\$75,898.07	55%	\$6,815.44	5%	\$462.62	0.33	\$789.42	1%
July	\$173,456.30	\$73,595.83	42%	\$0.00	0%	\$88,394.44	51%	\$4,498.82	3%	\$0.00	0.00	\$6,967.21	4%
August	\$139,231.48	\$57,583.89	41%	\$0.00	0%	\$75,690.58	54%	\$2,425.73	2%	\$83.76	0.06	\$3,615.04	3%
September	\$100,295.72	\$33,174.82	33%	\$0.00	0%	\$61,567.98	61%	\$2,266.11	2%	\$0.00	0.00	\$3,286.81	3%
October	\$120,726.14	\$46,559.76	39%	\$0.00	0%	\$64,339.38	53%	\$2,233.30	2%	\$622.70	0.52	\$8,216.40	7%
November	\$122,516.90	\$49,126.77	40%	\$0.00	0%	\$67,913.85	55%	\$4,551.35	4%	\$0.00	0.00	\$924.93	1%
December	\$125,378.60	\$42,174.54	34%	\$0.00	0%	\$71,908.46	57%	\$4,734.59	4%	\$439.37	0.35	\$7,000.38	6%
<b>Annual Total</b>	<b>\$1,595,766.24</b>	<b>\$624,557.63</b>	<b>39.1%</b>	<b>\$0.00</b>	<b>0.0%</b>	<b>\$896,806.50</b>	<b>56.2%</b>	<b>\$37,921.06</b>	<b>2.4%</b>	<b>\$2,101.82</b>	<b>0.1%</b>	<b>\$38,582.87</b>	<b>2.4%</b>

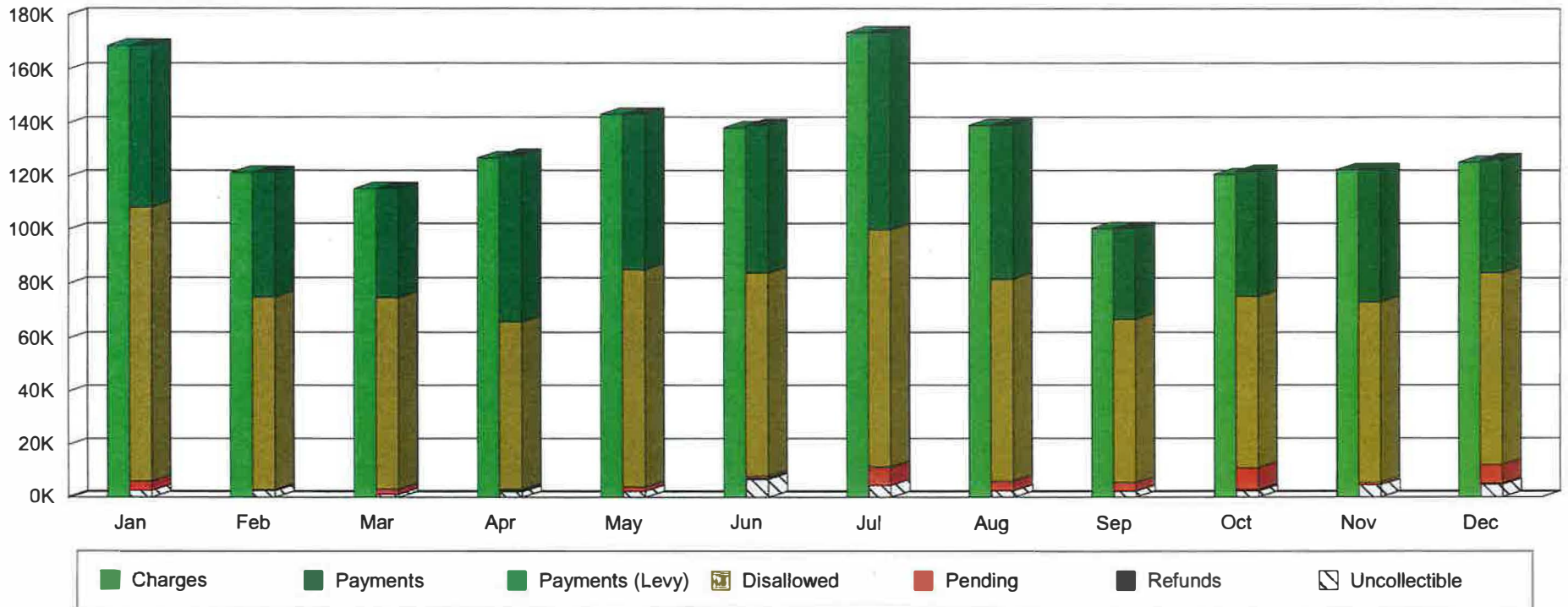

### Sheridan Fire District 2019 ANNUAL COLLECTION STATISTICS

Month	Charges	Payments	% Payments (Levy)	% Disallowed	% Uncollected	% Refunds	% Pending
July	\$0.00	\$0.00	0%	\$0.00	0%	\$0.00	0%
August	\$103,177.52	\$29,117.23	28%	\$0.00	0%	\$47,273.39	46%
September	\$122,968.58	\$25,026.71	20%	\$0.00	0%	\$58,710.01	48%
October	\$117,471.17	\$36,656.29	31%	\$0.00	0%	\$63,485.97	54%
November	\$108,719.37	\$20,583.22	19%	\$0.00	0%	\$45,324.98	42%
December	\$128,855.71	\$14,008.10	11%	\$0.00	0%	\$31,682.72	25%
<b>Annual Total</b>	<b>\$581,192.35</b>	<b>\$125,391.55</b>	<b>21.6%</b>	<b>\$0.00</b>	<b>0.0%</b>	<b>\$246,477.07</b>	<b>42.4%</b>

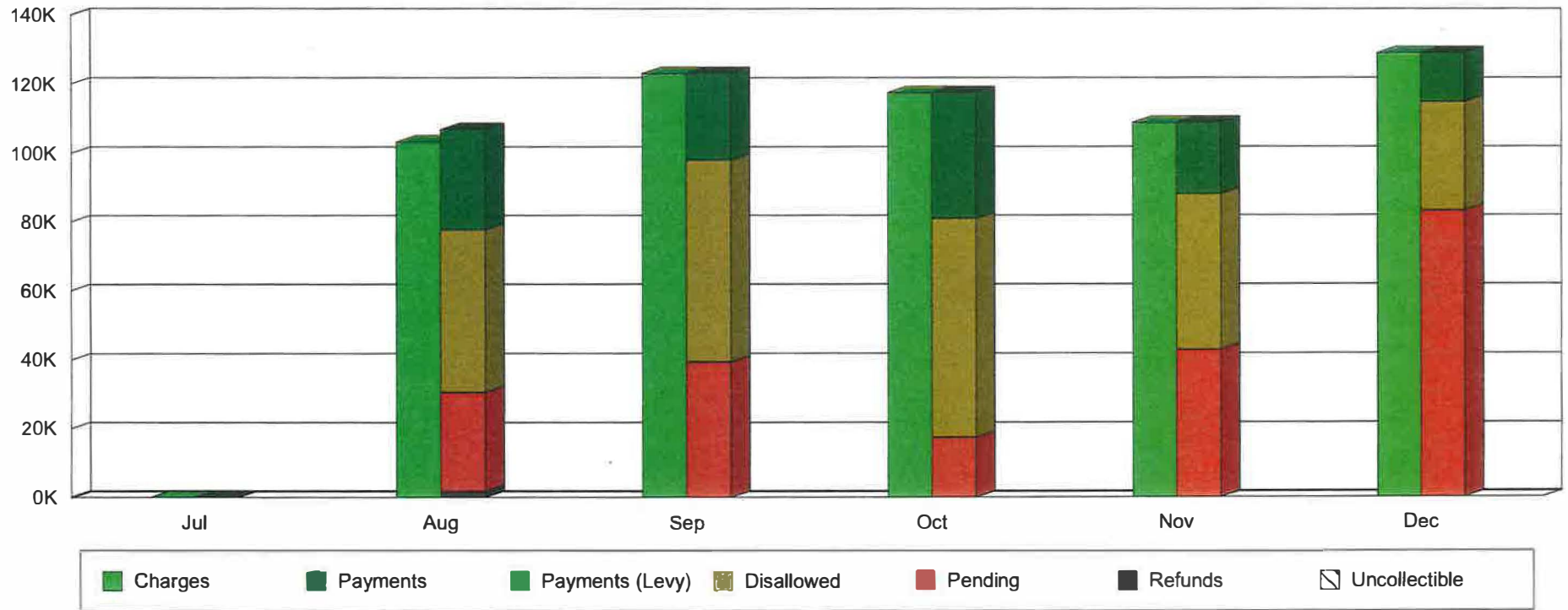

# Sheridan Fire District

Cash Report Fund Balance

January 31, 2020

For February 2020 Board Meeting

	BALANCE	DEPOSIT	WITHDRAWAL	INTEREST	FEES	BALANCE	
Checking/First Federal	\$ 66,941.28	\$486,572.25	-\$202,083.67	\$0.00	\$0.00	\$ 351,429.86	√
LGIP	\$ 1,102,826.41	\$8,885.71	\$0.00	\$2,114.67	-\$0.05	\$ 1,113,826.74	√
Checking/US Bank	\$ 160,475.56	\$29,152.96	-\$43.15	\$1.46	\$0.00	\$ 189,586.83	√
Petty Cash	\$ 56.00	\$0.00	\$0.00	\$0.00	\$0.00	\$ 56.00	√
<b>Totals</b>	\$ 1,330,299.25	\$524,610.92	\$ (202,126.82)	\$ 2,116.13	\$ (0.05)	\$ 1,654,899.43	

√ Indicates reconciled to statement

## Sheridan Rural Fire Protection District

## Profit &amp; Loss

02/04/20

January 2020

Cash Basis

	Jan 20
<b>Income</b>	
R1 · General Fund revenue	
Contractual Services	443,506.89
Current Taxes	8,664.90
Yamhill/Polk Prior Taxes	1,395.41
403000 · Interest Income	1.46
403002 · Interest Earned Taxes	2,161.61
404000 · Misc. Income	618.87
407000 · User Fees	36,487.69
<b>Total R1 · General Fund revenue</b>	<b>492,836.83</b>
<b>Total Income</b>	<b>492,836.83</b>
<b>Gross Profit</b>	<b>492,836.83</b>
<b>Expense</b>	
001 · General Fund	
02 · Material and Services	
Dispatch & Radio Services	2,482.25
Equipment	306.00
General Supplies	1,856.50
Miscellaneous	124.25
PPE & Uniforms	1,010.62
Professional Fees	-15,026.61
Repairs & Maintenance	13,702.57
Travel & Education	1,933.58
Utilities	3,883.01
200650 · EMS Supplies	3,105.71
<b>Total 02 · Material and Services</b>	<b>13,377.88</b>
<b>Total 001 · General Fund</b>	<b>13,377.88</b>
007 · John Fancher Memorial	
2100070 · J.F.M. Individual Awards	200.00
<b>Total 007 · John Fancher Memorial</b>	<b>200.00</b>
01 · Payroll	
Administrative Staff	54,363.57
Firefighter/Paramedic & EMT's	44,740.23
100057 · Payroll Expenses -Over Time -	9,929.41
104500 · Workers' Compensation	46.37
104600 · Health Insurance	27,108.77
104700 · FICA	8,341.04
104800 · PERS	19,292.01
104900 · Unemployment Insurance	324.57
01 · Payroll - Other	-0.01
<b>Total 01 · Payroll</b>	<b>164,145.96</b>
<b>Total Expense</b>	<b>177,723.84</b>
<b>Net Income</b>	<b>315,112.99</b>

**Sheridan Rural Fire Protection District**  
**Profit & Loss Budget vs. Actual**  
July 2019 through January 2020

	<u>Jul '19 - Jan 20</u>	<u>Budget</u>	<u>\$ Over Budget</u>	<u>% of Budget</u>
<b>Income</b>				
<b>R1 · General Fund revenue</b>				
Contractual Services	443,506.89	797,000.00	-353,493.11	55.6%
Current Taxes	643,440.37	653,000.00	-9,559.63	98.5%
Yamhill/Polk Prior Taxes	10,328.41	20,000.00	-9,671.59	51.6%
401501 · General Fund Begining Balance	768,656.00	550,000.00	218,656.00	139.8%
403000 · Interest Income	8.99			
403002 · Interest Earned Taxes	16,123.51			
404000 · Misc. Income	3,198.87	64,000.00	-60,801.13	5.0%
407000 · User Fees	331,987.04	650,000.00	-318,012.96	51.1%
<b>Total R1 · General Fund revenue</b>	<u>2,217,250.08</u>	<u>2,734,000.00</u>	<u>-516,749.92</u>	<u>81.1%</u>
<b>R5 · Gen. Equipment Reserve Fund</b>				
3200050 · G.E.R. ending balance	427,525.00	392,525.00	35,000.00	108.9%
4050050 · G.E.R. Transfer Gen-Fund	0.00	25,000.00	-25,000.00	0.0%
<b>Total R5 · Gen. Equipment Reserve Fund</b>	<u>427,525.00</u>	<u>417,525.00</u>	<u>10,000.00</u>	<u>102.4%</u>
<b>R7 · John Fancher Memorial Fund Rev.</b>				
3200070 · J.F.M. Ending fund bal.	5,327.00	5,427.00	-100.00	98.2%
<b>Total R7 · John Fancher Memorial Fund Rev.</b>	<u>5,327.00</u>	<u>5,427.00</u>	<u>-100.00</u>	<u>98.2%</u>
<b>R8 · Building Maint. Fund Revenue</b>				
Seismic Grant Income	0.00	1,310,470.00	-1,310,470.00	0.0%
3200080 · B.M. F. Ending Fund Balance	304,256.00	304,256.00	0.00	100.0%
<b>Total R8 · Building Maint. Fund Revenue</b>	<u>304,256.00</u>	<u>1,614,726.00</u>	<u>-1,310,470.00</u>	<u>18.8%</u>

**Sheridan Rural Fire Protection District**  
**Profit & Loss Budget vs. Actual**  
July 2019 through January 2020

	<u>Jul '19 - Jan 20</u>	<u>Budget</u>	<u>\$ Over Budget</u>	<u>% of Budget</u>
<b>R9 · Station 9 Spending Authority</b>				
Miscellaneous Income	0.00	2,000.00	-2,000.00	0.0%
Transfer in - General Fund	0.00	25,000.00	-25,000.00	0.0%
<b>Total R9 · Station 9 Spending Authority</b>	<u>0.00</u>	<u>27,000.00</u>	<u>-27,000.00</u>	<u>0.0%</u>
<b>Total Income</b>	<u>2,954,358.08</u>	<u>4,798,678.00</u>	<u>-1,844,319.92</u>	<u>61.6%</u>
<b>Gross Profit</b>	2,954,358.08	4,798,678.00	-1,844,319.92	61.6%
<b>Expense</b>				
001 · General Fund				
02 · Material and Services				
Dispatch & Radio Services	17,375.75	33,000.00	-15,624.25	52.7%
Equipment	-212.34	26,000.00	-26,212.34	-0.8%
Equipment Testing	5,589.01	20,000.00	-14,410.99	27.9%
General Supplies	6,346.37	25,000.00	-18,653.63	25.4%
Grant	0.00	20,000.00	-20,000.00	0.0%
Miscellaneous	5,831.04	10,500.00	-4,668.96	55.5%
PPE & Uniforms	8,780.27	31,500.00	-22,719.73	27.9%
Professional Fees	24,648.68	35,000.00	-10,351.32	70.4%
Repairs & Maintenance	77,422.07	100,000.00	-22,577.93	77.4%
Travel & Education	5,726.89	25,000.00	-19,273.11	22.9%
Utilities	19,180.95	30,500.00	-11,319.05	62.9%
200650 · EMS Supplies	17,197.51	25,000.00	-7,802.49	68.8%
200800 · Insurance	6,033.00	35,000.00	-28,967.00	17.2%
<b>Total 02 · Material and Services</b>	<u>193,919.20</u>	<u>416,500.00</u>	<u>-222,580.80</u>	<u>46.6%</u>

**Sheridan Rural Fire Protection District**  
**Profit & Loss Budget vs. Actual**  
July 2019 through January 2020

	<u>Jul '19 - Jan 20</u>	<u>Budget</u>	<u>\$ Over Budget</u>	<u>% of Budget</u>
<b>05 · Transfers</b>				
500300 · Building Maintenance	0.00	25,000.00	-25,000.00	0.0%
500600 · General Equip. Reserve Fund	0.00	25,000.00	-25,000.00	0.0%
<b>Total 05 · Transfers</b>	<u>0.00</u>	<u>50,000.00</u>	<u>-50,000.00</u>	<u>0.0%</u>
<b>06 · Contingency</b>				
600100 · Contingency	0.00	50,000.00	-50,000.00	0.0%
<b>Total 06 · Contingency</b>	<u>0.00</u>	<u>50,000.00</u>	<u>-50,000.00</u>	<u>0.0%</u>
<b>Total 001 · General Fund</b>	193,919.20	516,500.00	-322,580.80	37.5%
<b>005 · General Equipment Reserve Fund</b>				
310151 · Total Gen Eq Res UEFB	0.00	417,525.00	-417,525.00	0.0%
<b>Total 005 · General Equipment Reserve Fund</b>	<u>0.00</u>	<u>417,525.00</u>	<u>-417,525.00</u>	<u>0.0%</u>
<b>007 · John Fancher Memorial</b>				
2100070 · J.F.M. Individual Awards	200.00	200.00	0.00	100.0%
2100071 · Total J Fancher Memorial UEFB	0.00	5,227.00	-5,227.00	0.0%
<b>Total 007 · John Fancher Memorial</b>	<u>200.00</u>	<u>5,427.00</u>	<u>-5,227.00</u>	<u>3.7%</u>
<b>008 · Building Maint. Fund</b>				
Seismic Grant Upgrades	0.00	1,310,470.00	-1,310,470.00	0.0%
2100080 · B.M.F. Repair and Upkeep Bldg.	0.00	250,000.00	-250,000.00	0.0%
2100081 · Total Building Maint UEFB	0.00	54,256.00	-54,256.00	0.0%
<b>Total 008 · Building Maint. Fund</b>	<u>0.00</u>	<u>1,614,726.00</u>	<u>-1,614,726.00</u>	<u>0.0%</u>
<b>009 · St. 9 Spending Authority</b>				
2100090 · Appreciation Program	1,826.79	27,000.00	-25,173.21	6.8%
<b>Total 009 · St. 9 Spending Authority</b>	<u>1,826.79</u>	<u>27,000.00</u>	<u>-25,173.21</u>	<u>6.8%</u>
<b>01 · Payroll</b>				
Administrative Staff	367,620.85	637,000.00	-269,379.15	57.7%
Firefighter/Paramedic & EMT's	303,532.04	684,000.00	-380,467.96	44.4%

**Sheridan Rural Fire Protection District**  
**Profit & Loss Budget vs. Actual**  
July 2019 through January 2020

	<u>Jul '19 - Jan 20</u>	<u>Budget</u>	<u>\$ Over Budget</u>	<u>% of Budget</u>
100057 · Payroll Expenses -Over Time -	30,232.16	50,000.00	-19,767.84	60.5%
100060 · RV Reimbursement	5,870.00	50,000.00	-44,130.00	11.7%
100061 · Part-Time	14,259.95	10,000.00	4,259.95	142.6%
104500 · Workers' Compensation	52,466.09	25,000.00	27,466.09	209.9%
104600 · Health Insurance	161,658.87	310,000.00	-148,341.13	52.1%
104700 · FICA	54,914.37	110,000.00	-55,085.63	49.9%
104800 · PERS	124,991.61	210,000.00	-85,008.39	59.5%
104900 · Unemployment Insurance	741.27	1,500.00	-758.73	49.4%
01 · Payroll - Other	-0.04			
<b>Total 01 · Payroll</b>	<u>1,116,287.17</u>	<u>2,087,500.00</u>	<u>-971,212.83</u>	<u>53.5%</u>
<b>07 · Unappropriated EFB</b>				
70000 · UEFB	0.00	130,000.00	-130,000.00	0.0%
<b>Total 07 · Unappropriated EFB</b>	<u>0.00</u>	<u>130,000.00</u>	<u>-130,000.00</u>	<u>0.0%</u>
<b>Total Expense</b>	<u>1,312,233.16</u>	<u>4,798,678.00</u>	<u>-3,486,444.84</u>	<u>27.3%</u>
<b>Net Income</b>	<u><u>1,642,124.92</u></u>	<u><u>0.00</u></u>	<u><u>1,642,124.92</u></u>	<u><u>100.0%</u></u>



Sheridan Rural Fire Protection District

Check Detail

January 2020  
Name

Type	Num	Date	Name	Account	Paid Amount
Check		01/02/2020		101500 · LGIP/5354 200900 · Prof Services and Elections	-0.05
Liability Check		01/13/2020	QuickBooks Payroll Service	18072 · First Federal Payroll Expenses	-136.00
				Payroll Expenses	-40.00
TOTAL					<u>-176.00</u>
Liability Check		01/21/2020	QuickBooks Payroll Service	18072 · First Federal Payroll Expenses	-1.75
				Payroll Expenses	-1.50
				Payroll Expenses	-109.00
			QuickBooks Payroll Service	2100 · Payroll Liabilities	-723.00
			QuickBooks Payroll Service	2100 · Payroll Liabilities	-75.39
			QuickBooks Payroll Service	2100 · Payroll Liabilities	-75.39
			QuickBooks Payroll Service	2100 · Payroll Liabilities	-322.35
			QuickBooks Payroll Service	2100 · Payroll Liabilities	-322.35
			QuickBooks Payroll Service	2100 · Payroll Liabilities	-366.00
			QuickBooks Payroll Service	2100 · Payroll Liabilities	-1.85
			QuickBooks Payroll Service	2100 · Payroll Liabilities	-1.85
			QuickBooks Payroll Service	2110 · Direct Deposit Liabilities	-3,626.33
			QuickBooks Payroll Service	2100 · Payroll Liabilities	-5.20
TOTAL					<u>-5,631.96</u>
Paycheck		01/22/2020	Fredrickson, Caleb J	18072 · First Federal 2110 · Direct Deposit Liabilities	3,263.70
				2110 · Direct Deposit Liabilities	362.63
TOTAL					<u>3,626.33</u>
Liability Check		01/30/2020	QuickBooks Payroll Service	18072 · First Federal Payroll Expenses	-31.50
				Payroll Expenses	-27.00
			QuickBooks Payroll Service	2100 · Payroll Liabilities	-10,129.00
			QuickBooks Payroll Service	2100 · Payroll Liabilities	-1,497.34
			QuickBooks Payroll Service	2100 · Payroll Liabilities	-1,497.34
			QuickBooks Payroll Service	2100 · Payroll Liabilities	-6,402.45
			QuickBooks Payroll Service	2100 · Payroll Liabilities	-6,402.45
			QuickBooks Payroll Service	2100 · Payroll Liabilities	-6,657.00

**Sheridan Rural Fire Protection District**  
**Check Detail**  
January 2020

TOTAL				-176.00
		QuickBooks Payroll Service	2100 · Payroll Liabilities	-44.02
		QuickBooks Payroll Service	2100 · Payroll Liabilities	-44.02
		QuickBooks Payroll Service	2110 · Direct Deposit Liabilities	-75,560.54
		QuickBooks Payroll Service	2100 · Payroll Liabilities	-102.44
TOTAL				<u>-108,395.10</u>
Liability Check	01/30/2020	QuickBooks Payroll Service	18072 · First Federal	
			Payroll Expenses	-1.75
			Payroll Expenses	-1.50
		QuickBooks Payroll Service	2100 · Payroll Liabilities	-8.25
		QuickBooks Payroll Service	2100 · Payroll Liabilities	-8.25
		QuickBooks Payroll Service	2100 · Payroll Liabilities	-35.26
		QuickBooks Payroll Service	2100 · Payroll Liabilities	-35.26
		QuickBooks Payroll Service	2100 · Payroll Liabilities	-19.00
		QuickBooks Payroll Service	2100 · Payroll Liabilities	-0.50
		QuickBooks Payroll Service	2100 · Payroll Liabilities	-0.50
		QuickBooks Payroll Service	2110 · Direct Deposit Liabilities	-505.17
		QuickBooks Payroll Service	2100 · Payroll Liabilities	-0.57
TOTAL				<u>-616.01</u>
Paycheck	01/31/2020	Breeden, Judy L	18072 · First Federal	
			2110 · Direct Deposit Liabilities	3,267.64
Paycheck	01/31/2020	Crowe, Jason R	18072 · First Federal	
			2110 · Direct Deposit Liabilities	5,088.98
Paycheck	01/31/2020	Cummins, Daniel L	18072 · First Federal	
			2110 · Direct Deposit Liabilities	3,821.99
Paycheck	01/31/2020	Elliott, Michael R	18072 · First Federal	
			2110 · Direct Deposit Liabilities	3,991.33
Paycheck	01/31/2020	Hammer, Donna E	18072 · First Federal	
			2110 · Direct Deposit Liabilities	4,470.31
Paycheck	01/31/2020	Hari, Brendan R	18072 · First Federal	
			2110 · Direct Deposit Liabilities	2,716.30
Paycheck	01/31/2020	Hertel, Frederick J	18072 · First Federal	

Sheridan Rural Fire Protection District

Check Detail

January 2020

TOTAL					-176.00
				2110 · Direct Deposit Liabilities	6,937.68
Paycheck	01/31/2020	Homer, Daniel B	18072 · First Federal		
			2110 · Direct Deposit Liabilities		3,213.82
Paycheck	01/31/2020	Hoxie, Sean R	18072 · First Federal		
			2110 · Direct Deposit Liabilities		6,000.36
Paycheck	01/31/2020	Ketelson, Andrew D	18072 · First Federal		
			2110 · Direct Deposit Liabilities		3,623.22
Paycheck	01/31/2020	Leigh, Zachariah A	18072 · First Federal		
			2110 · Direct Deposit Liabilities		3,519.73
Paycheck	01/31/2020	Malcomson, Ronald P	18072 · First Federal		
			2110 · Direct Deposit Liabilities		1,815.21
Paycheck	01/31/2020	Mock, Robert C	18072 · First Federal		
			2110 · Direct Deposit Liabilities		5,028.90
Paycheck	01/31/2020	Pozzesi, Nicholas M	18072 · First Federal		
			2110 · Direct Deposit Liabilities		3,508.00
Paycheck	01/31/2020	Prescott, Mariah N	18072 · First Federal		
			2110 · Direct Deposit Liabilities		2,701.80
Paycheck	01/31/2020	Ryan, Suzanna R	18072 · First Federal		
			2110 · Direct Deposit Liabilities		1,311.76
			2110 · Direct Deposit Liabilities		1,967.63
TOTAL					<u>3,279.39</u>
Paycheck	01/31/2020	Schulze, Damon R	18072 · First Federal		
			2110 · Direct Deposit Liabilities		6,474.36
Paycheck	01/31/2020	Thomas, Leslie E	18072 · First Federal		
			2110 · Direct Deposit Liabilities		6,101.52
Paycheck	01/31/2020	Neville, Grace M	18072 · First Federal		
			2110 · Direct Deposit Liabilities		505.17

**Sheridan Rural Fire Protection District**  
**Check Detail**  
January 2020

TOTAL						-176.00
	Bill Pmt -Check Bill	Online	01/02/2020 12/11/2019	CenturyLink	18072 · First Federal 202300 · Telephone	-213.41
	Bill Pmt -Check Bill	Online	01/03/2020 12/12/2019	Verizon Wireless	18072 · First Federal 202300 · Telephone	-275.10
	Check	Online	01/03/2020	Citi Cards	18072 · First Federal Citi VISA/9805 JB citi/VISA 3867FH	-3,370.70 -250.47
TOTAL						<u>-3,621.17</u>
	Bill Pmt -Check Bill	Online	01/06/2020 0329987 11/04/2019	Bretthauer Oil Co.	18072 · First Federal 200500 · Fuel & Oil 200500 · Fuel & Oil	-710.88 -471.41
TOTAL						<u>-1,182.29</u>
	Bill Pmt -Check Bill	Online	01/07/2020 12/18/2019	PGE	18072 · First Federal 202200 · Electricity	-100.85
	Liability Check	Online	01/09/2020	West Valley Local 4861	18072 · First Federal 2100 · Payroll Liabilities	-700.00
	Liability Check	Online	01/09/2020	Oregon Department of Justice	18072 · First Federal 2100 · Payroll Liabilities	-234.00
	Liability Check	Online	01/09/2020	Employee Benefits Service Trust	18072 · First Federal 2100 · Payroll Liabilities 2100 · Payroll Liabilities	-1,257.53 -27,122.74
TOTAL						<u>-28,380.27</u>
	Check	Online	01/10/2020	Cardmember Service	18072 · First Federal Cardmember Service/9404JB	-682.35
	Bill Pmt -Check Bill	Online	01/10/2020 12/23/2019	PGE	18072 · First Federal 202200 · Electricity	-122.42
	Bill Pmt -Check Bill	Online	01/10/2020 12/23/2019	PGE	18072 · First Federal 202200 · Electricity	-600.55

Sheridan Rural Fire Protection District

Check Detail

January 2020

TOTAL						
Bill Pmt -Check Bill	Online	01/13/2020 12/27/2019	Crystal Springs	18072 · First Federal 202720 · Janitorial & House Supplies	-176.00 -54.43	
Bill Pmt -Check Bill	Online	01/13/2020 12/26/2019	NW Natural Gas	18072 · First Federal 202100 · Natural Gas	-774.78	
Bill Pmt -Check Bill	Online	01/13/2020 12/27/2019	City of Sheridan	18072 · First Federal 202000 · Water & Sewer	-173.49	
Bill Pmt -Check Bill	Online	01/14/2020 12/27/2019	NW Natural Gas	18072 · First Federal 202100 · Natural Gas	-90.10	
Liability Check	Online	01/15/2020	Aflac	18072 · First Federal 2100 · Payroll Liabilities	-140.01	
Bill Pmt -Check Bill	Online	01/15/2020 12/31/2019	Perrydale Domestic Water Assn	18072 · First Federal 202000 · Water & Sewer	-40.00	
Bill Pmt -Check Bill	Online	01/17/2020 12/31/2019	Western Oregon Waste	18072 · First Federal 203100 · Garbage Collection	-185.66	
Bill Pmt -Check Bill	Online	01/21/2020 12/25/2019	Ferrellgas	18072 · First Federal 202100 · Natural Gas	-141.45	
Check	Online	01/21/2020	Intuit Inc.	691 · US Bank 202600 · Office Supplies & Postage	-43.15	
Bill Pmt -Check Bill	Online	01/23/2020 12/26/2019	Buell-Red Prairie Water District	18072 · First Federal 202000 · Water & Sewer	-59.27	
Bill Pmt -Check Bill	Online	01/23/2020 12/28/2019	CenturyLink	18072 · First Federal 202300 · Telephone	-50.04	
Bill Pmt -Check Bill	Online	01/27/2020 01/02/2020	Rogers, Dennis	18072 · First Federal 200500 · Fuel & Oil	-116.63	
Check	Online	01/27/2020	Public Employees Retirement System	18072 · First Federal 104800 · PERS	-19,292.01	
Liability Check	Online	01/30/2020	Nationwide Retirement Solutions	18072 · First Federal		

**Sheridan Rural Fire Protection District**  
**Check Detail**  
January 2020

TOTAL					2100 · Payroll Liabilities	-176.00 -850.00
Bill Pmt -Check	Online	01/31/2020	Canon Solutions America	18072 · First Federal		
Bill		01/13/2020		202600 · Office Supplies & Postage		-180.21
				202600 · Office Supplies & Postage		-40.52
				202600 · Office Supplies & Postage		-33.81
TOTAL						<u>-254.54</u>
Check	26040	01/09/2020	DeJong, Jack.	18072 · First Federal		
				2100070 · J.F.M. Individual Awards		-100.00
Check	26041	01/09/2020	Hoopingarner, Christopher	18072 · First Federal		
				2100070 · J.F.M. Individual Awards		-100.00
Check	26042	01/09/2020	Oregon Dept. of Revenue	18072 · First Federal		
				104900 · Unemployment Insurance		-324.57
Bill Pmt -Check	26043	01/09/2020	Bretthauer Oil Co.	18072 · First Federal		
Bill	0331592	12/02/2019		200500 · Fuel & Oil		-398.13
				200500 · Fuel & Oil		-160.09
Bill	0332360	12/16/2019		200500 · Fuel & Oil		-374.14
				200500 · Fuel & Oil		-287.09
Bill	332903	12/30/2019		200500 · Fuel & Oil		-593.69
				200500 · Fuel & Oil		-398.08
Bill		01/03/2020		200500 · Fuel & Oil		-522.50
TOTAL						<u>-2,733.72</u>
Bill Pmt -Check	26044	01/09/2020	Davison Auto Parts	18072 · First Federal		
Bill		12/24/2019		200710 · Vehicle Maintenance		-211.72
Bill Pmt -Check	26045	01/09/2020	EF Recovery LLC	18072 · First Federal		
Bill	Nov	12/12/2019		200900 · Prof Services and Elections		-1,317.60
				200900 · Prof Services and Elections		-56.65
TOTAL						<u>-1,374.25</u>
Bill Pmt -Check	26046	01/09/2020	Fire Resue Equipment NW, LLC	18072 · First Federal		
Bill	2200	12/07/2019		200610 · Fire Equipment & Hose		-200.00
Bill	2199	12/07/2019		200610 · Fire Equipment & Hose		-106.00
TOTAL						<u>-306.00</u>

Sheridan Rural Fire Protection District

Check Detail

January 2020

TOTAL						-176.00
Bill Pmt -Check	26047	01/09/2020	HR Answers, Inc.	18072 · First Federal		
Bill	40/40/20	12/13/2019		200900 · Prof Services and Elections		-5,400.00
Bill Pmt -Check	26048	01/09/2020	Industrial Welding Supply, Inc.	18072 · First Federal		
Bill	85452	12/30/2019		200650 · EMS Supplies		-44.25
Bill Pmt -Check	26049	01/09/2020	Labsource, Inc.	18072 · First Federal		
Bill		12/13/2019		200650 · EMS Supplies		-179.25
Bill Pmt -Check	26050	01/09/2020	Life-Assist, Inc.	18072 · First Federal		
Bill	SFD	12/02/2019		200650 · EMS Supplies		-544.16
Bill	WVFD	12/02/2019		200650 · EMS Supplies		-27.48
Bill	WVFD	12/02/2019		200650 · EMS Supplies		-475.50
Bill	962029	12/13/2019		200650 · EMS Supplies		-530.22
Bill	WVFD	12/16/2019		200650 · EMS Supplies		-210.00
Bill	WVFD	12/16/2019		200650 · EMS Supplies		-164.64
Bill	WVFD	12/16/2019		200650 · EMS Supplies		-297.45
Bill	963248	12/20/2019		200650 · EMS Supplies		-286.00
Bill	963614	12/23/2019		200650 · EMS Supplies		-355.21
Bill	964679	12/30/2019		200650 · EMS Supplies		-325.12
Bill	WVFD	12/31/2019		200650 · EMS Supplies		-381.82
TOTAL						<u>-3,597.60</u>
Bill Pmt -Check	26051	01/09/2020	Runge, Sylvia	18072 · First Federal		
Bill	Elliott, M	12/30/2019		202400 · Uniforms		-24.00
Bill Pmt -Check	26052	01/09/2020	Streamline	18072 · First Federal		
Bill	Dec	12/13/2019		203800 · Computer Programs and Maint.		-200.00
Bill Pmt -Check	26053	01/09/2020	Systems Management	18072 · First Federal		
Bill	8022	09/24/2019		202710 · Bldg. Maint. Sup. and Grounds		-1,236.22
Bill Pmt -Check	26054	01/09/2020	Walter E Nelson Co	18072 · First Federal		
Bill	40/40/20	12/06/2019		202720 · Janitorial & House Supplies		-36.92
Bill	1452951	12/20/2019		202720 · Janitorial & House Supplies		-236.85
				202720 · Janitorial & House Supplies		-339.71
				202720 · Janitorial & House Supplies		-163.53
Bill	1453922	12/26/2019		202720 · Janitorial & House Supplies		-364.96
				202720 · Janitorial & House Supplies		-166.21

**Sheridan Rural Fire Protection District**  
**Check Detail**  
January 2020

TOTAL					202720 · Janitorial & House Supplies	-176.00
	Bill	1453971	12/26/2019		202720 · Janitorial & House Supplies	-66.25
TOTAL						<u>-132.50</u>
						-1,506.93
	<b>Bill Pmt -Check</b>	<b>26055</b>	<b>01/09/2020</b>	<b>West Valley Fire District</b>	<b>18072 · First Federal</b>	
	Bill		01/06/2020		202710 · Bldg. Maint. Sup. and Grounds	-1,430.00
					202710 · Bldg. Maint. Sup. and Grounds	-344.99
					200500 · Fuel & Oil	-14.40
					General Supplies	-50.37
					202710 · Bldg. Maint. Sup. and Grounds	-340.98
					202710 · Bldg. Maint. Sup. and Grounds	-4,178.04
					General Supplies	-53.96
					General Supplies	-72.99
					202710 · Bldg. Maint. Sup. and Grounds	-12.49
					Repairs & Maintenance	-481.33
					General Supplies	<u>-352.53</u>
TOTAL						-7,332.08
	<b>Bill Pmt -Check</b>	<b>26056</b>	<b>01/09/2020</b>	<b>WFCA the Daily Dispatch</b>	<b>18072 · First Federal</b>	
	Bill	40/40/20	12/27/2019		203400 · Advertising	-405.00
	<b>Bill Pmt -Check</b>	<b>26057</b>	<b>01/09/2020</b>	<b>Yamhill Communication Agency</b>	<b>18072 · First Federal</b>	
	Bill	January	12/16/2019		Dispatch & Radio Services	-2,482.25
	<b>Bill Pmt -Check</b>	<b>26058</b>	<b>01/09/2020</b>	<b>ZOLL Medical Corp.</b>	<b>18072 · First Federal</b>	
	Bill		12/30/2019		200650 · EMS Supplies	-841.50
	<b>Bill Pmt -Check</b>	<b>26059</b>	<b>01/21/2020</b>	<b>Crowe, Jason</b>	<b>18072 · First Federal</b>	
	Bill	St 97	12/30/2019		202710 · Bldg. Maint. Sup. and Grounds	-158.37
	<b>Bill Pmt -Check</b>	<b>26060</b>	<b>01/21/2020</b>	<b>DMV-Driver and Motor Vehicle Services</b>	<b>18072 · First Federal</b>	
	Bill		12/31/2019		200900 · Prof Services and Elections	-3.00
	<b>Bill Pmt -Check</b>	<b>26061</b>	<b>01/21/2020</b>	<b>Sheridan Building Materials</b>	<b>18072 · First Federal</b>	
	Bill	St 97	12/19/2019		202710 · Bldg. Maint. Sup. and Grounds	-5.99
	<b>Bill Pmt -Check</b>	<b>26062</b>	<b>01/21/2020</b>	<b>Wire Works LLC</b>	<b>18072 · First Federal</b>	
	Bill	new BR198	11/06/2019		200710 · Vehicle Maintenance	-12,160.86



Sheridan Rural Fire Protection District

Checktail

January 2020

TOTAL						-176.00
	Check	26063	01/23/2020	Salt Creek Church	18072 · First Federal 203820 · Awards and incentives	-450.00
	Liability Check	26064	01/31/2020	Oregon Department of Justice	18072 · First Federal 2100 · Payroll Liabilities	-234.00
TOTAL						<u>294,300.69</u>

# SW Polk Fire District

Cash Report Fund Balance

January 31, 2020

For February 2020 Board Meeting

	BALANCE	DEPOSIT	WITHDRAWAL	INTEREST	FEES	BALANCE	
District/Columbia Bank	\$ 15,598.71	\$613,323.47	-\$581,252.45	\$0.00	-\$25.00	\$ 47,644.73	√
Volunteer/Columbia Bank	\$ 25,735.23	\$3,435.59	-\$3,098.41	\$0.00	\$0.00	\$ 26,072.41	√
LGIP/4884	\$ 1,818,445.44	\$6,891.46	-\$613,323.47	\$2,796.75	-\$0.05	\$ 1,214,810.13	√
LGIP/6043	\$ 4,545,158.61	\$313,323.47	\$0.00	\$8,969.53	\$0.00	\$ 4,867,451.61	√
<b>Totals</b>	\$ 6,404,937.99	\$936,973.99	\$ (1,197,674.33)	\$ 11,766.28	\$ (25.05)	\$ 6,155,978.88	

√ Indicates reconciled to statement
-------------------------------------

2:34 PM  
02/03/20  
Cash Basis

SW Polk Fire District  
Profit & Loss  
January 2020

	<u>Jan 20</u>
<b>Income</b>	
4200 · Current Property Tax	5,304.27
4210 · Deliquent Property Tax	1,395.15
4310 · Interest on Investments	11,958.32
4830 · Miscellaneous Revenue	3,435.59
<b>Total Income</b>	<u>22,093.33</u>
<b>Gross Profit</b>	22,093.33
<b>Expense</b>	
6000 · Materials & Services	
General Supplies	1,035.36
PPE	1,854.24
Repairs & Maintenance	6,782.64
Travel & Education	1,839.88
Utilities	1,296.58
6400 · Firefighter Appreciation	3,648.41
6463 · Contractual Services	247,304.54
6465 · Legal/Professional Fees	7,696.44
6600 · Miscellaneous	47.68
<b>Total 6000 · Materials &amp; Services</b>	<u>271,505.77</u>
<b>Total Expense</b>	<u>271,505.77</u>
<b>Net Income</b>	<u><u>-249,412.44</u></u>

**SW Polk Fire District**  
**Profit & Loss Budget vs. Actual**  
 July 2019 through January 2020

	Jul '19 - Jan 20	Budget	\$ Over Budget	% of Budget
<b>Income</b>				
4200 · Current Property Tax	818,897.62	863,300.00	-44,402.38	94.9%
4210 · Delinquent Property Tax	16,858.48	15,000.00	1,858.48	112.4%
4310 · Interest on Investments	88,368.62	100,000.00	-11,631.38	88.4%
4830 · Miscellaneous Revenue	26,893.09	55,000.00	-28,106.91	48.9%
4949 · Transfer In GF-Firefighter	0.00	27,740.00	-27,740.00	0.0%
4990 · Beginning Balance	0.00	6,551,540.00	-6,551,540.00	0.0%
<b>Total Income</b>	<b>951,017.81</b>	<b>7,612,580.00</b>	<b>-6,661,562.19</b>	<b>12.5%</b>
<b>Gross Profit</b>	<b>951,017.81</b>	<b>7,612,580.00</b>	<b>-6,661,562.19</b>	<b>12.5%</b>
<b>Expense</b>				
4999 · Unappropriated Ending Fund Bal	0.00	720,000.00	-720,000.00	0.0%
5000 · Personnel				
5063 · Workers Compensation	0.00	5,000.00	-5,000.00	0.0%
<b>Total 5000 · Personnel</b>	<b>0.00</b>	<b>5,000.00</b>	<b>-5,000.00</b>	<b>0.0%</b>
6000 · Materials & Services				
Dispatch Services	13,751.25	54,000.00	-40,248.75	25.5%
Equipment Testing & Maint.	3,349.39	28,000.00	-24,650.61	12.0%
General Supplies	2,179.74	5,000.00	-2,820.26	43.6%
PPE	7,300.09	10,000.00	-2,699.91	73.0%
Repairs & Maintenance	24,269.22	9,500.00	14,769.22	255.5%
Travel & Education	2,440.38	4,000.00	-1,559.62	61.0%
Utilities	4,598.84	8,500.00	-3,901.16	54.1%
6400 · Firefighter Appreciation	13,466.44	56,740.00	-43,273.56	23.7%
6455 · Insurance-Property/Liab	5,163.90	15,000.00	-9,836.10	34.4%
6463 · Contractual Services	247,745.14	471,600.00	-223,854.86	52.5%
6465 · Legal/Professional Fees	25,557.86	27,500.00	-1,942.14	92.9%
6500 · Equipment	0.00	5,000.00	-5,000.00	0.0%
6515 · General Purpose Grant Expense	0.00	5,000.00	-5,000.00	0.0%
6600 · Miscellaneous	2,509.45	5,000.00	-2,490.55	50.2%
6000 · Materials & Services - Other	0.00	0.00	0.00	0.0%
<b>Total 6000 · Materials &amp; Services</b>	<b>352,331.70</b>	<b>704,840.00</b>	<b>-352,508.30</b>	<b>50.0%</b>
7000 · Debt Service				
7466 · Bond Issuance Costs	0.00	0.00	0.00	0.0%
7801 · Series 2017 Debt Serv Principal	195,000.00	195,000.00	0.00	100.0%
7802 · Series 2017 Debt Serv Interest	101,661.86	200,000.00	-98,338.14	50.8%
<b>Total 7000 · Debt Service</b>	<b>296,661.86</b>	<b>395,000.00</b>	<b>-98,338.14</b>	<b>75.1%</b>

3:47 PM

02/03/20

Cash Basis

**SW Polk Fire District**  
**Profit & Loss Budget vs. Actual**  
July 2019 through January 2020

	Jul '19 - Jan 20	Budget	\$ Over Budget	% of Budget
<b>8000 · Capital Outlay</b>				
8500 · Firefighting & Safety Equip	0.00	100,000.00	-100,000.00	0.0%
8501 · Apparatus Replacement	206.85	2,351,000.00	-2,350,793.15	0.0%
8502 · Faciliites (Stations)	254,863.95	3,259,000.00	-3,004,136.05	7.8%
<b>Total 8000 · Capital Outlay</b>	255,070.80	5,710,000.00	-5,454,929.20	4.5%
<b>9901 · Transfer to Station 130</b>	0.00	27,740.00	-27,740.00	0.0%
<b>9970 · Contingency</b>	50,000.00	50,000.00	0.00	100.0%
<b>Total Expense</b>	954,064.36	7,612,580.00	-6,658,515.64	12.5%
<b>Net Income</b>	<b>-3,046.55</b>	<b>0.00</b>	<b>-3,046.55</b>	<b>100.0%</b>

**SW Polk Fire District  
Check Detail  
January 2020**

Type	Num	Date	Name	Account	Paid Amount
Check		01/02/2020		1007 · LGIP 4884	
				6600 · Miscellaneous	-0.05
TOTAL					-0.05
Check		01/15/2020		1008 · SW - 9840 Columbia B...	
				6600 · Miscellaneous	-25.00
TOTAL					-25.00
Bill Pmt -Check	Online	01/02/2020	CenturyLink	1008 · SW - 9840 Columbia B...	
Bill		12/13/2019		Utilities	-163.45
TOTAL					-163.45
Bill Pmt -Check	Online	01/21/2020	Pacific Power	1008 · SW - 9840 Columbia B...	
Bill		01/03/2020		Utilities	-245.35
TOTAL					-245.35
Bill Pmt -Check	Online	01/22/2020	Spectrum Business	1008 · SW - 9840 Columbia B...	
Bill		01/09/2020		Utilities	-64.98
TOTAL					-64.98
Check	Online	01/24/2020	Bank of America	1009 · VOLS - 9832 Columbia...	
				4050 · Donations	-18.49
				4090 · Nominal Gifts	-120.90
				4030 · Building	-19.84
				4040 · Business Meeting	-205.54
				4060 · Equipment	-6.98
				4080 · LOS Gifts	-368.48
				4110 · Operations	-110.28
				4140 · Parking	-247.90
TOTAL					-1,098.41

**SW Polk Fire District**  
**Check Detail**  
 January 2020

Type	Num	Date	Name	Account	Paid Amount
Bill Pmt -Check	Online	01/31/2020	CenturyLink	1008 · SW - 9840 Columbia B...	
Bill		01/13/2020		Utilities	-162.33
TOTAL					-162.33
Check	205	01/23/2020	Sheridan Volunteer Firefighter Assc.	1009 · VOLS - 9832 Columbia...	
				4020 · Awards Banquet	-2,000.00
TOTAL					-2,000.00
Check	206	01/27/2020	Polk County Fair	1009 · VOLS - 9832 Columbia...	
				4150 · Polk County Fair	-550.00
TOTAL					-550.00
Bill Pmt -Check	6102	01/09/2020	City of Dallas	1008 · SW - 9840 Columbia B...	
Bill	E137	12/16/2019		Repairs & Maintenance	-400.44
Bill	E137	12/16/2019		Repairs & Maintenance	-1,213.78
TOTAL					-1,614.22
Bill Pmt -Check	6103	01/09/2020	DPSST	1008 · SW - 9840 Columbia B...	
Bill	Gillins	03/19/2019		Travel & Education	-40.00
TOTAL					-40.00
Bill Pmt -Check	6104	01/09/2020	Itemizer-Observer	1008 · SW - 9840 Columbia B...	
Bill		11/30/2019		6465 · Legal/Professional Fees	-40.00
TOTAL					-40.00
Bill Pmt -Check	6105	01/09/2020	MNOP	1008 · SW - 9840 Columbia B...	
Bill	CL12650	12/15/2019		Repairs & Maintenance	-383.70
TOTAL					-383.70

**SW Polk Fire District**  
**Check Detail**  
 January 2020

Type	Num	Date	Name	Account	Paid Amount
Bill Pmt -Check	6106	01/09/2020	Perrydale Domestic Water Assc.	1008 · SW - 9840 Columbia B...	
Bill		12/31/2019		Utilities	-40.00
TOTAL					-40.00
Bill Pmt -Check	6107	01/09/2020	Sheridan Rural Fire Protection District	1008 · SW - 9840 Columbia B...	
Bill		01/06/2020		6465 · Legal/Professional Fees	-50.00
				General Supplies	-163.53
				General Supplies	-597.42
Bill		01/06/2020		6463 · Contractual Services	-247,304.54
				General Supplies	-165.23
				6465 · Legal/Professional Fees	-7,478.36
				Travel & Education	-346.79
				PPE	-423.21
				Repairs & Maintenance	-3,970.14
TOTAL					-260,499.22
Bill Pmt -Check	6108	01/09/2020	West Valley Fire District	1008 · SW - 9840 Columbia B...	
Bill		01/06/2020		6465 · Legal/Professional Fees	-50.00
				Repairs & Maintenance	-66.84
				PPE	-302.91
Bill	40/40/2...	01/06/2020		6465 · Legal/Professional Fees	-38.08
				Travel & Education	-1,433.09
				PPE	-1,128.12
				General Supplies	-109.18
				Repairs & Maintenance	-276.88
				Utilities	-377.95
				6600 · Miscellaneous	-22.63
TOTAL					-3,805.68
Bill Pmt -Check	6109	01/09/2020	Weaver, Brad.	1008 · SW - 9840 Columbia B...	
Bill		12/21/2019		Travel & Education	-20.00
TOTAL					-20.00



**SW Polk Fire District  
Check Detail  
January 2020**

Type	Num	Date	Name	Account	Paid Amount
Bill Pmt -Check	6110	01/09/2020	Crowe, Jason	1008 · SW - 9840 Columbia B...	
Bill	St 140	12/30/2020		Repairs & Maintenance	-299.00
TOTAL					-299.00
Bill Pmt -Check	6111	01/09/2020	Dallas Auto Parts	1008 · SW - 9840 Columbia B...	
Bill		12/31/2019		Repairs & Maintenance	-9.70
TOTAL					-9.70
Bill Pmt -Check	6112	01/09/2020	Itemizer-Observer	1008 · SW - 9840 Columbia B...	
Bill		12/31/2019		6465 · Legal/Professional Fees	-40.00
TOTAL					-40.00
Bill Pmt -Check	6113	01/09/2020	MNOP	1008 · SW - 9840 Columbia B...	
Bill	CL14949	12/31/2019		Repairs & Maintenance	-461.16
TOTAL					-461.16
Bill Pmt -Check	6114	01/09/2020	NW Natural	1008 · SW - 9840 Columbia B...	
Bill	St 130	12/31/2019		Utilities	-177.52
TOTAL					-177.52
Bill Pmt -Check	6115	01/09/2020	Rickreall Community Water	1008 · SW - 9840 Columbia B...	
Bill		01/06/2020		Utilities	-21.50
				Utilities	-43.50
TOTAL					-65.00

**West Valley**  
**ANNUAL COLLECTION STATISTICS**

Company	West Valley
Date Of Service	1/1/2019
Date Of Service	12/31/2019
Invoices	0
Provider	West Valley

Month	Tickets	Charges	Payments	%	FireMed	%	Disallowed	%	Uncollected	%	Pending	%
Jan 19	62	107,958.20	-36,018.47	33 %	-625.00	1 %	-62,233.37	58 %	-5,311.80	5 %	3,769.56	3 %
Feb 19	67	116,544.00	-46,001.54	39 %	-500.00	0 %	-64,181.14	55 %	-5,709.40	5 %	151.92	0 %
Mar 19	51	89,664.80	-34,138.81	38 %	0.00	0 %	-44,622.15	50 %	-5,840.44	7 %	5,063.40	6 %
Apr 19	62	106,788.20	-35,993.03	34 %	-150.00	0 %	-54,069.81	51 %	-1,405.56	1 %	15,169.80	14 %
May 19	80	135,731.20	-38,342.39	28 %	-1,635.60	1 %	-70,874.26	52 %	-3,222.64	2 %	21,656.31	16 %
Jun 19	72	125,567.40	-42,456.07	34 %	-925.00	1 %	-57,149.90	46 %	-142.06	0 %	24,894.37	20 %
Jul 19	73	130,667.20	-41,933.33	32 %	-250.00	0 %	-57,273.86	44 %	-159.22	0 %	31,050.79	24 %
Aug 19	65	117,289.00	-34,993.56	30 %	-1,052.47	1 %	-43,311.84	37 %	0.00	0 %	37,931.13	32 %
Sep 19	82	135,750.00	-41,386.44	30 %	-1,000.00	1 %	-50,619.93	37 %	0.00	0 %	42,743.63	31 %
Oct 19	73	125,521.00	-31,957.72	25 %	0.00	0 %	-53,156.48	42 %	0.00	0 %	40,406.80	32 %
Nov 19	56	102,760.60	-19,563.29	19 %	-275.00	0 %	-36,630.47	36 %	0.00	0 %	46,291.84	45 %
Dec 19	65	111,876.40	-11,298.02	10 %	0.00	0 %	-26,980.75	24 %	0.00	0 %	73,597.63	66 %

**808      1,406,118.00      -414,082.67      -6,413.07      -621,103.96      -21,791.12      342,727.18**

**All amounts shown relate directly to each month's charges. They will not reconcile to monthly deposit reports**

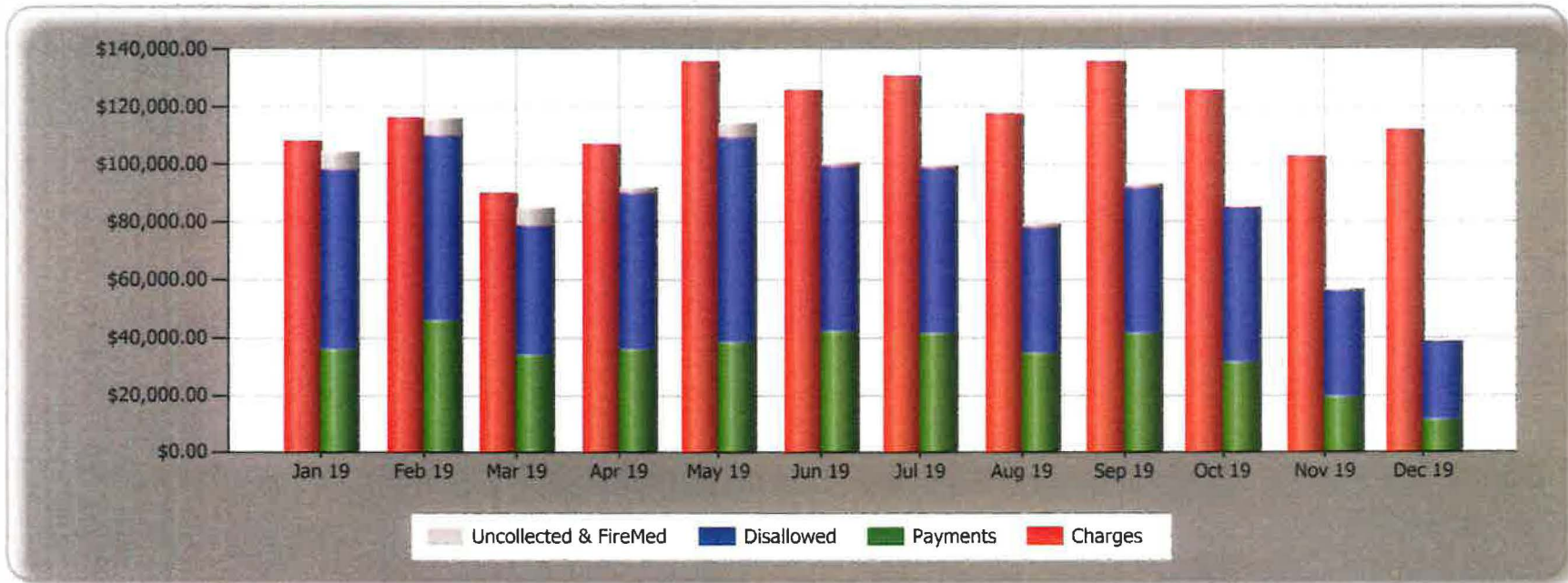

# West Valley Fire District

Cash Report Fund Balance

January 31, 2020

For February 2020 Board Meeting

	BALANCE	DEPOSIT	WITHDRAWAL	INTEREST	FEEs	BALANCE	
US Bank Checking	\$ 31,505.02	\$370,636.57	-\$339,100.32	\$0.00	-\$8.00	\$ 63,033.27	√
LGIP/5640	\$ 362,994.37	\$3,579.37	-\$320,000.00	\$330.62	\$0.00	\$ 46,904.36	√
<b>Totals</b>	\$ 394,499.39	\$374,215.94	\$ (659,100.32)	\$ 330.62	\$ (8.00)	\$ 109,937.63	

√ Indicates reconciled to statement
-------------------------------------

# West Valley Fire District

## PROFIT AND LOSS

January 2020

	TOTAL
Income	
INCOME	
600 Current Taxes	2,880.96
610 Previous Taxes	667.88
615 Interest	361.15
620 Ambulance User Fees	39,202.31
625 FireMed	375.00
627 Miscellaneous	485.10
<b>Total INCOME</b>	<b>43,972.40</b>
Unapplied Cash Payment Income-1	5.00
<b>Total Income</b>	<b>\$43,977.40</b>
<b>GROSS PROFIT</b>	<b>\$43,977.40</b>
Expenses	
MATERIAL & SERVICES	
807 Dispatch Fees	1,836.42
812 Professional Services	21,379.75
814 Misc. Expenses	-5.25
826 Utilities	3,662.85
835 Medical Supplies	2,195.46
Contractual Services	196,202.35
General Supplies	676.04
PPE	12,161.90
Repairs & Maintenance	6,460.55
Travel & Education	-2,088.85
<b>Total MATERIAL &amp; SERVICES</b>	<b>242,481.22</b>
PAYROLL EXPENSES	
Health Ins. Contribution	10,095.54
P.E.R.S.	8,781.64
Salaries	
6560 Salaries	36,667.98
<b>Total Salaries</b>	<b>36,667.98</b>
Social Security/Medicare	13,864.32
State Taxes (Employee)	4,286.36
<b>Total PAYROLL EXPENSES</b>	<b>73,695.84</b>
<b>Total Expenses</b>	<b>\$316,177.06</b>
<b>NET OPERATING INCOME</b>	<b>\$ -272,199.66</b>
<b>NET INCOME</b>	<b>\$ -272,199.66</b>

# West Valley Fire District

## BUDGET VS. ACTUALS: FY\_2019\_2020 - FY20 P&L

July 2019 - January 2020

	TOTAL			
	ACTUAL	BUDGET	REMAINING	% OF BUDGET
Income				
GF Beginning Balance	329,005.46	375,000.00	45,994.54	87.73 %
<b>INCOME</b>				
600 Current Taxes	250,272.80	255,000.00	4,727.20	98.15 %
610 Previous Taxes	10,029.03	5,000.00	-5,029.03	200.58 %
615 Interest	2,732.05		-2,732.05	
620 Ambulance User Fees	346,055.57	650,000.00	303,944.43	53.24 %
625 FireMed	6,140.00		-6,140.00	
627 Miscellaneous	760.10	50,000.00	49,239.90	1.52 %
630 Contractural services	244,011.84	550,000.00	305,988.16	44.37 %
646 Equipment Sale	10,843.00		-10,843.00	
<b>Total INCOME</b>	<b>870,844.39</b>	<b>1,510,000.00</b>	<b>639,155.61</b>	<b>57.67 %</b>
Unapplied Cash Payment Income-1	5.00		-5.00	
<b>Total Income</b>	<b>\$1,199,854.85</b>	<b>\$1,885,000.00</b>	<b>\$685,145.15</b>	<b>63.65 %</b>
<b>GROSS PROFIT</b>	<b>\$1,199,854.85</b>	<b>\$1,885,000.00</b>	<b>\$685,145.15</b>	<b>63.65 %</b>
Expenses				
<b>MATERIAL &amp; SERVICES</b>				
807 Dispatch Fees	18,347.75	33,000.00	14,652.25	55.60 %
808 Insurance	1,636.00	35,000.00	33,364.00	4.67 %
812 Professional Services	69,993.81	25,000.00	-44,993.81	279.98 %
814 Misc. Expenses	4,808.24	10,000.00	5,191.76	48.08 %
826 Utilities	22,291.54	32,000.00	9,708.46	69.66 %
835 Medical Supplies	16,488.70	35,000.00	18,511.30	47.11 %
Contractual Services	196,202.35	355,000.00	158,797.65	55.27 %
Equipment	511.01	16,000.00	15,488.99	3.19 %
General Supplies	7,919.03	25,000.00	17,080.97	31.68 %
Grant Purchases	10,000.00	20,000.00	10,000.00	50.00 %
PPE	22,878.59	18,000.00	-4,878.59	127.10 %
Repairs & Maintenance	53,454.26	60,000.00	6,545.74	89.09 %

	TOTAL			
	ACTUAL	BUDGET	REMAINING	% OF BUDGET
Travel & Education	7,835.42	15,000.00	7,164.58	52.24 %
<b>Total MATERIAL &amp; SERVICES</b>	<b>432,366.70</b>	<b>679,000.00</b>	<b>246,633.30</b>	<b>63.68 %</b>
PAYROLL EXPENSES	561,964.40	1,106,000.00	544,035.60	50.81 %
Unapplied Cash Bill Payment Expense	0.00		0.00	
Unappropriated Ending Fund Balance		75,000.00	75,000.00	
<b>Total Expenses</b>	<b>\$994,331.10</b>	<b>\$1,860,000.00</b>	<b>\$865,668.90</b>	<b>53.46 %</b>
NET OPERATING INCOME	<b>\$205,523.75</b>	<b>\$25,000.00</b>	<b>\$ -180,523.75</b>	<b>822.10 %</b>
Other Expenses				
OTHER EXPENDITURES				
Contingency		25,000.00	25,000.00	
<b>Total OTHER EXPENDITURES</b>		<b>25,000.00</b>	<b>25,000.00</b>	
<b>Total Other Expenses</b>	<b>\$0.00</b>	<b>\$25,000.00</b>	<b>\$25,000.00</b>	<b>0.00%</b>
NET OTHER INCOME	<b>\$0.00</b>	<b>\$ -25,000.00</b>	<b>\$ -25,000.00</b>	<b>0.00 %</b>
NET INCOME	<b>\$205,523.75</b>	<b>\$0.00</b>	<b>\$ -205,523.75</b>	<b>0.00%</b>

# West Valley Fire District

## CHECK DETAIL

January 2020

DATE	TRANSACTION TYPE	NUM	NAME	MEMO/DESCRIPTION	AMOUNT
1 US Bank					
01/02/2020	Bill Payment (Check)	Online	CenturyLink		-304.11
					-304.11
01/02/2020	Check	5113	Department of Justice	410000000187701 410000000187701	-16.00 -16.00
01/02/2020	Check	5114	IAFF Local 4861	December payroll December payroll	-700.00 -700.00
01/03/2020	Expense			ELECTRONIC WITHDRAWAL Bill.com Download from usbank.com.	-21,728.62 21,728.62
01/03/2020	Expense		Oregon Department of Revenue	ELECTRONIC WITHDRAWAL Payroll Download from usbank.com.	-3,529.50 3,529.50
01/07/2020	Expense			OVERDRAFT PAID FEE Download from usbank.com.	-36.00 36.00
01/07/2020	Expense			ELECTRONIC WITHDRAWAL IRS Download from usbank.com.	-13,799.18 13,799.18
01/09/2020	Bill Payment (Check)	5121	Grand Ronde Sanitary District		-40.00 -40.00
01/09/2020	Bill Payment (Check)	5116	Bretthauer Oil Company		-192.43 -192.43
01/09/2020	Bill Payment (Check)	5117	Bulletin Board, The		-57.00 -57.00
01/09/2020	Bill Payment (Check)	5119	City of Willamina		-254.68 -254.68
01/09/2020	Bill Payment (Check)	5120	Grand Ronde Community Water		-48.00 -48.00
01/09/2020	Bill Payment (Check)	5124	MES - Northwest		-915.09 -915.09
01/09/2020	Bill Payment (Check)	5127	Sheridan Fire Distirct		-
					216,586.62
					216,586.62
01/09/2020	Bill Payment (Check)	5128	Skyberg's Lumber & Hardware		-93.53

DATE	TRANSACTION TYPE	NUM	NAME	MEMO/DESCRIPTION	AMOUNT
					-93.5'
01/09/2020	Bill Payment (Check)	5115	A & E Security & Electronic Solutions		-149.85
					-149.85
01/09/2020	Bill Payment (Check)	5122	Industrial Welding Supply, INC		-109.00
					-109.00
01/09/2020	Bill Payment (Check)	5123	John Heiser, MD		-3,000.00
					-3,000.00
01/09/2020	Bill Payment (Check)	5126	Sheldon Oil Company		-1,758.95
					-1,758.95
01/09/2020	Bill Payment (Check)	5129	Special Districts Insurance Services		-10,095.54
					-10,095.54
01/09/2020	Bill Payment (Check)	5118	City Of Dallas	01-08-0151	-327.85
					-327.85
01/09/2020	Bill Payment (Check)	5125	MES - Northwest		-4,886.50
					-4,886.5'
01/09/2020	Expense		Oregon Department of Revenue	ELECTRONIC WITHDRAWAL PAYROLL Download from usbank.com.	-373.14
					373.14
01/10/2020	Bill Payment (Check)	Online	Recology Western Oregon	1080134460	-100.34
					-100.34
01/13/2020	Bill Payment (Check)	Online	NW Natural	1007944-0	-705.06
					-705.06
01/14/2020	Bill Payment (Check)	Online	Wave Broadband		-59.72
					-59.72
01/14/2020	Expense		Oregon Department of Revenue	ELECTRONIC WITHDRAWAL Payroll Download from usbank.com.	-19.40
					19.40
01/14/2020	Expense		Oregon Department of Revenue	ELECTRONIC WITHDRAWAL Payroll Download from usbank.com.	-153.41
					153.41
01/14/2020	Expense		Oregon Department of Revenue	ELECTRONIC WITHDRAWAL Payroll Download from usbank.com.	-210.91
					210.91
01/15/2020	Bill Payment (Check)	Online	Sierra Springs	587930312816707	-221.60
					-221.€
01/15/2020	Expense			ANALYSIS SERVICE CHARGE Download from usbank.com.	-8.00
					8.00



DATE	TRANSACTION TYPE	NUM	NAME	MEMO/DESCRIPTION	AMOUNT
01/15/2020	Expense				-65.14
				ELECTRONIC WITHDRAWAL IRS Download from usbank.com.	65.14
01/16/2020	Bill Payment (Check)	Online	Verizon Wireless		-680.58
					-680.58
01/16/2020	Bill Payment (Check)	Online	Portland General Electric		-1,444.87
					-1,444.87
01/16/2020	Check	Online	AFLAC MED		-77.52
				December	-47.88
					-29.64
01/17/2020	Bill Payment (Check)	Online	Wave Business	8136 20 023 0013530	-124.41
					-124.41
01/17/2020	Bill Payment (Check)	Online	Portland General Electric		-29.87
					-29.87
01/17/2020	Check	Online	US Bank	11/22/19-12/19/19	-10,550.26
					-507.00
					-143.44
					-2,858.82
					-2,701.89
					-14.93
					-4,324.18
01/23/2020	Bill Payment (Check)	5130	Carquest Of Sheridan	78570	-13.59
					-13.59
01/23/2020	Bill Payment (Check)	5131	Willamina Select Market	2004	-29.43
					-29.43
01/27/2020	Expense		PERS		-2.43
				ELECTRONIC WITHDRAWAL EMPLOYER C Download from usbank.com. EMPLOYER CONTRB	2.43
01/27/2020	Expense		PERS		-2,558.50
				ELECTRONIC WITHDRAWAL EMPLOYER C Download from usbank.com. EMPLOYER CONTRB	2,558.50
01/27/2020	Expense		PERS		-6,220.71
				ELECTRONIC WITHDRAWAL EMPLOYER C Download from usbank.com. EMPLOYER CONTRB	6,220.71
01/28/2020	Expense		Intuit Complete Payroll		-123.00
				ELECTRONIC WITHDRAWAL Payroll Se Download from usbank.com. Payroll Service	123.00
01/30/2020	Check	Online	Dial Long Distance		-43.14
				193650927	43.14
01/30/2020	Expense		RAYMOND G WATKINS		-4,561.73

DATE	TRANSACTION TYPE	NUM	NAME	MEMO/DESCRIPTION	AMOUNT
				ELECTRONIC WITHDRAWAL PAYROLL Download from usbank.com.	4,561.77
01/30/2020	Expense		MICHAELA B WOODS		-4,080.15
				ELECTRONIC WITHDRAWAL PAYROLL Download from usbank.com.	4,080.15
01/30/2020	Expense		ERIC M HINES		-4,004.68
				ELECTRONIC WITHDRAWAL PAYROLL Download from usbank.com.	4,004.68
01/30/2020	Expense		TAMI L TIGNER		-3,923.34
				ELECTRONIC WITHDRAWAL PAYROLL Download from usbank.com.	3,923.34
01/30/2020	Expense		RYAN J VAUBLE		-3,751.43
				ELECTRONIC WITHDRAWAL PAYROLL Download from usbank.com.	3,751.43
01/30/2020	Expense		McKENNA HOY		-3,666.08
				ELECTRONIC WITHDRAWAL PAYROLL Download from usbank.com.	3,666.08
01/30/2020	Expense		JAKOB P SESSA		-3,599.85
				ELECTRONIC WITHDRAWAL PAYROLL Download from usbank.com.	3,599.85
01/30/2020	Expense		JACOB W ALGUIRE		-3,298.14
				ELECTRONIC WITHDRAWAL PAYROLL Download from usbank.com.	3,298.14
01/30/2020	Expense		COOPER T WALTERS		-3,047.60
				ELECTRONIC WITHDRAWAL PAYROLL Download from usbank.com.	3,047.60
01/30/2020	Expense		JAY PAYNE		-2,734.98
				ELECTRONIC WITHDRAWAL PAYROLL Download from usbank.com.	2,734.98
01/31/2020	Check	5134	IAFF Local #4861	10 employees (Jan. 2020) January 2020	-700.00 -700.00
01/31/2020	Check	5133	Department of Justice	410000000187701 410000000187701	-16.00 -16.00
01/31/2020	Check	5132	Department of Justice	410000000372703 410000000372703	-514.00 -514.00
01/31/2020	Bill Payment (Check)	5135	City of Willamina	1303.03	-260.11 -260.11
Bill.com Money Out Clearing					
01/03/2020	Bill Payment (Check)		Industrial Welding Supply, INC	Inv #N/A	-50.00 -50.00
01/03/2020	Bill Payment (Check)		Gormley Plumbing and Mechanical (deleted)	Inv #78124S	-945.00 -945.00
01/03/2020	Bill Payment (Check)		Municipal Emergency Services,INC	Inv #IN1395510	-5,521.64 -5,521.64
01/03/2020	Bill Payment (Check)		Complete Wireless Solutions	Inv #S93253	-33.50 -33.50

DATE	TRANSACTION TYPE	NUM	NAME	MEMO/DESCRIPTION	AMOUNT
01/03/2020	Bill Payment (Check)		Life-Assist Inc.	Inv #957149	-164.72
					-164.72
01/03/2020	Bill Payment (Check)		Northwest Safety Clean	Inv #19-25718	-1,449.45
					-1,449.45
01/03/2020	Bill Payment (Check)		Northwest Safety Clean	Inv #19-25719	-799.05
					-799.05
01/03/2020	Bill Payment (Check)		Systems Design West, LLC	Acct #WV0219 - Inv #20191603	-1,902.25
					-1,902.25
01/03/2020	Bill Payment (Check)		Carquest Of Sheridan	Inv #RB9285999403	-23.98
					-23.98
01/03/2020	Bill Payment (Check)		Skyberg's Lumber & Hardware	Inv #RB9285999407	-87.20
					-87.20
01/03/2020	Bill Payment (Check)		Bulletin Board, The	Inv #4793	-56.25
					-56.25
01/03/2020	Bill Payment (Check)		City Of Dallas	Acct #01-08-0151 - Inv #RB9283564888	-4,693.90
					-4,693.90
01/03/2020	Bill Payment (Check)		Grand Ronde Community Water	Inv #RB9285999402	-24.00
					-24.00
01/03/2020	Bill Payment (Check)		City Of Dallas	Acct #01-08-0151 - Inv #2871	-1,440.89
					-1,440.89
01/03/2020	Bill Payment (Check)		Zoll Medical Corporation	Acct #155785 - Inv #2983072	-314.85
					-314.85
01/03/2020	Bill Payment (Check)		Bretthauer Oil Company	Inv #N/A	-74.52
					-74.52
01/03/2020	Bill Payment (Check)		Bretthauer Oil Company	Inv #N/A	-80.33
					-80.33
01/03/2020	Bill Payment (Check)		News-Register	Inv #102576	-79.75
					-79.75
01/03/2020	Bill Payment (Check)		Systems Design West, LLC	Acct #WV0219 - Inv #N/A	-1,323.95
					-1,323.95

DATE	TRANSACTION TYPE	NUM	NAME	MEMO/DESCRIPTION	AMOUNT
01/03/2020	Bill Payment (Check)		Yamhill Communications Agency	Acct #YCOM-WVFD - Inv #N/A	-1,836.42
					-1,836.42

# West Valley Fire District



## Special Workshop: General Operational Levy February 3, 2020 Minutes

Called Meeting to Order: 4:07 pm

Pledge of Allegiance

Roll Call:

Chris Greenhill (present)

Roy Whitman (present)

Gary Brooks (present)

Jack Mishler (present)

Don Shelton (present)

Fred Hertel (present)

Audience:

Damon Schulze

Melissa Ivey

Called to order 4:09 PM

Discussed the five completed forms for public relations ("Who is West Valley Fire District?", "How is West Valley Staffed?", "How is West Valley Funded?", "How does West Valley use its Funding?" and "What is the relationship between the Confederated Tribes of Grand Ronde and West Valley?")

Discussed the importance of community involvement and education.

Adjourned at 6: 10 PM.

Respectfully submitted,

Mariah Prescott

# SOUTHWESTERN POLK COUNTY RURAL FIRE PROTECTION DISTRICT

## INVITATION TO BID

Contractors are invited to bid on the construction of one or more of these fire station (Project(s)) for Southwestern Polk County Rural Fire Protection District (District). The stations to be built are located at:

Rickreall Fire Station – 9105 Rickreall Road Rickreall, OR 97371  
Salt Creek Fire Station - 15455 Salt Creek Road Dallas, OR 97338  
Bridgeport Fire Station – 6040 S Kings Valley Highway Dallas, OR 97338

The Rickreall and Salt Creek Fire Stations will be approximately 5,000 sq. ft., including three apparatus bays, , office, and other essential areas. The District has outstanding grant applications which may provide funding for additional area buildouts for one or more of the fire station projects. **District reserves the right to award one, two or all three station projects to any one Bidder, based on individual station or aggregate bid amounts.** Sealed bids will be received by Fred Hertel, Fire Chief at PO Box 6 or 230 SW Mill Street, Sheridan, OR 97378 at or before 2:00 p.m., March 10, 2020. Bids will be publicly opened immediately following this closing.

This contract is for a public work subject to ORS 279C.800 to 279C.870, relating to the payment of prevailing wages.

No prequalification will be required for this Project.

The terms, conditions and specifications for this Project (Project Documents) may be examined at Southwestern Polk County Rural Fire Protection District (District) office located at PO Box 6 or 230 SW Mill Street, Sheridan, OR 97378, between the hours of 9:00 a.m. to 4:00 p.m., Monday through Friday until March 10, 2020. The Project Documents will be available at this location and are downloadable from the District website at <https://swpolkfire.org/> from the date of this Notice until March 10, 2020. Copies may be obtained from the District for a non-refundable fee of \$250.00.

---

Fred Hertel, Fire Chief  
Southwestern Polk County Rural Fire Protection District  
230 SW Mill Street  
Sheridan, OR 97378

# INSTRUCTIONS TO BIDDERS

Bids will be received by Southwestern Polk County Rural Fire Protection District (hereinafter called "District") at PO Box 6 or 230 SW Mill Street, Sheridan, OR 97378, until 2:00 p.m., Pacific Daylight Time, March 10, 2020. Bids will be publicly opened immediately following this closing.

Each bid must be submitted in an opaque, sealed envelope, addressed to Fred Hertel, Fire Chief, Southwestern Polk County Rural Fire Protection District, at the above address. Each bid must be plainly marked on the outside of the envelope with the name of the bidder, the District's address and "Station Construction Project." Bids not so marked may be disqualified. If forwarded by mail, the sealed envelope containing the bid must be contained in another envelope addressed to the District at the address listed above. Faxed or electronically submitted bids shall be refused as non-responsive.

This contract is for a public work subject to ORS 279C.800 to 279C.870, relating to the payment of prevailing wages.

No prequalification will be required for this Project.

No pre-bid conference will be held.

Contract terms, conditions and Project specifications for this Project (Project Documents) may be examined at the District office located at 230 SW Mill Street, Sheridan, OR 97378 or downloaded from the District website at <https://swpolkfire.org/>. Copies of the Project Documents may be obtained from the District for a non-refundable fee of \$250.00.

All bids must be submitted on the required bid form. All blank spaces for bid prices must be completed in ink and the bid form must be fully completed and executed when submitted. Only one copy of the bid form is required. To be considered, each bid must be accompanied by a bid bond or certified check in the amount of 10% of the bid.

Contractor must comply with all federal, state, and local laws or regulations dealing with the prevention of environmental pollution and preservation of natural resources that affect the performance of the Contract.

## 1. Non-Compliant Bids

The District may reject any bid not in compliance with all prescribed public bidding procedures and requirements. Any bid failing to certify compliance with ORS 279C.800 to 279C.870 *et seq.* will not be received or considered by District. All bids must identify whether the bidder is a resident bidder as defined in ORS 279A.120. The District may reject for good cause any and all bids upon finding it is in the public interest to do so. Any bid may be withdrawn prior to the above scheduled time for the opening of bids, or any authorized postponement per District Public Contracting Rule (District Rule) 137-049-0320. Any bid received after the closing time and date specified above shall not be

considered. No bidder may withdraw a bid within forty (40) days after the actual date of the bid opening. Should there be reasons why the contract cannot be awarded within the specified time, the time may be extended by mutual agreement between the District and the bidder.

## 2. Bidder Responsibilities

Before submitting a bid, each bidder must:

- (a) Examine the contract documents thoroughly;
- (b) Visit the site, so that the bidder may familiarize itself with local conditions which may, in any manner, affect cost progress, or performance of the Work;
- (c) Be familiar with state, federal, and local laws, ordinances, rules and regulations which may, in any manner, affect cost, progress or performance of the Work; and
- (d) Study and carefully correlate bidder's observations with the contract documents.

## 3. Instructions for First-Tier Subcontractor Disclosure

Bidders are required to disclose information about certain first-tier subcontractors when the contract value for a Public Improvement is greater than \$100,000 (see ORS 279C.370). Specifically, when the contract amount of a first-tier subcontractor furnishing labor or labor and materials would be greater than or equal to: (i) 5% of the Project Bid, but at least \$15,000, or (ii) \$350,000 regardless of the percentage, the bidder must disclose the following information about that subcontract either in its Bid submission, or within two hours after Bid Closing:

- (a) The subcontractor's name;
- (b) The category of work that the subcontractor would be performing, and
- (c) The dollar value of the subcontract.

If the bidder will not be using any subcontractors that are subject to the above disclosure requirements, the bidder is required to indicate "NONE" on the accompanying form.

THE CONTRACTING AGENCY MUST REJECT A BID IF THE BIDDER FAILS TO SUBMIT THE DISCLOSURE FORM WITH THIS INFORMATION BY THE STATED DEADLINE (see District Rule 137-049-0360).

## 4. The Importance of Bids and Contract Documents

The submission of a bid will constitute an incontrovertible representation by the bidder: (1) of bidder's intent to be bound by the attached contract documents, if awarded the contract; (2) that the bidder has complied with each of the requirements within these bid documents; (3) that the contract documents are sufficient in scope and detail to indicate and convey understanding of all terms and conditions for performance of the Work; and



(4) of bidder's intent to sign up to two contract amendments to include Stations 130 and/or 150, upon negotiation of a contract price acceptable to District.. The plans for the Project provide bidders a delineated description of the land owned and the area involving easements. Bidders are to scrupulously follow these boundaries and not encroach upon, in any manner, property owned by any other person.

The contract documents contain the provisions required for the construction of the Project. Information obtained from an officer, agent, or employee of the District or any other person is not binding upon the District, and shall not affect the risks or obligations assumed by the Contractor or relieve Contractor from fulfilling any conditions of this solicitation or the contract, once executed, unless confirmed by written addendum or contract amendment.

5. Requests for Clarification/Addenda

All questions about the meaning or intent of the contract documents shall be submitted to the District representative in writing. If merited, replies may be issued by addendum, mailed or delivered to all parties recorded by the District representative as having received the bidding documents, per District Rule 137-049-0250. Requests for changes and clarifications shall be submitted in accordance with District Rule 137-049-0260. Only questions answered by formal written addenda will be binding. Oral and other interpretations or clarifications will be without legal effect.

6. Performance and Payment Bonds

A performance bond and a payment bond, in the forms attached, each in the amount of 100% of the contract price, with a corporate surety approved by the District, will be required for the faithful performance of the contract. Attorneys in fact who sign bid bonds or payment bonds and performance bonds must file with each bond a certified and effective dated copy of their Power of Attorney. All bonding companies must be authorized to do business in the State of Oregon.

7. District Investigation of Bidder

The District may make such investigations as deemed necessary to determine the ability of the bidder to perform work. In determining the lowest responsible bidder, District shall check the list created by the Construction Contractors Board under ORS 701.227 for bidders who are not qualified to hold a public improvement contract and determine whether the bidder has met the standards of responsibility. District shall also consider the following factors and may disqualify any person as a bidder if it finds the bidder:

- (a) Does not have available the appropriate financial, material, equipment, facility and personnel resources and expertise, or the ability to obtain the resources and expertise, necessary to meet all contractual responsibilities;
- (b) Does not hold a current license that a contractor operating in Oregon must hold in order to undertake or perform Project Work;

- (c) Is not covered by liability insurance or other insurance in required amounts;
- (d) Does not qualify as a carrier insured employer or a self-insured employer under ORS 656.407 or has not elected coverage under ORS 656.128;
- (e) Failed to provide a First-Tier Subcontractor Disclosure Form, if required under ORS 279C.370;
- (f) Does not have a satisfactory record of performance. The District shall document the record of performance of a bidder if the District finds the bidder not to be responsible under this paragraph (f);
- (g) Does not have a satisfactory record of integrity. The District shall document the record of integrity of a bidder if the District finds the bidder not to be responsible under this paragraph (g);
- (h) Is not qualified legally to contract with the District; or
- (i) Has not supplied all necessary information in connection with the inquiry concerning responsibility.

Each bidder shall promptly supply information as requested by the District pursuant to such investigation. If a bidder fails to promptly supply information requested by the District concerning responsibility, the District shall base the determination of responsibility upon any available information, or may find the bidder not to be responsible. Failure to supply such information may be grounds for disqualification.

#### 8. Registration and Licenses

No bid for a construction contract shall be received or considered by the District unless the bidder is registered and in good standing with the Construction Contractors Board or licensed and in good standing with the State Landscape Contractors Board, as required by ORS 671.530. Bidders need not be licensed to work with asbestos, under ORS 468A.720.

#### 9. Protests

Award and solicitation protests shall be submitted in accordance with District Rule 137-049-0260(3) and 137-049-0450(4), respectively.

#### 10. Process

At least seven (7) days prior to final award, all bidders will receive the District's Notice of Intent to Award issued via email. The District anticipates final Contract award on or before March 20, 2020.

The bidder to whom the contract is awarded will be required to execute the attached agreement and obtain the performance and payment bonds within ten (10) calendar days from the date when Notice of Award is delivered to the bidder. Submittal of a bid indicates bidder's intent to be bound to all terms and conditions of the attached agreement. The Notice of Award shall be accompanied by the necessary agreement and bond forms. In case of a failure of the bidder to execute the agreement, the District

may, at its option, consider the bidder in default in which case the bid bond accompanying the bid shall become the property of the District.

The District, within ten (10) days of receipt of an acceptable performance bond, an acceptable payment bond, and the required agreements signed by the successful bidder, including proof of insurance as required by the contract documents, shall sign and return to the successful bidder an executed duplicate of the agreement and notice to proceed. If the 10-day notice to proceed has not been issued within the 10-day period, or within a period mutually agreed upon, the Contractor may terminate the agreement without further liability on the party of either party. Such termination shall be by written notices and will be effective upon receipt by the District.

The award of one, two or all three stations will be made to the lowest responsible bidder, based upon individual station or aggregate bid amounts. The Contractor shall submit to the District representative by the last calendar day of each month a partial payment estimate for work performed during the prior pay period. The cutoff date for work performed shall be the 26th day of the month in which a payment estimate is submitted. The District will approve and authorize payment of partial payment estimates approved by the District representative at its regular monthly District meeting.

District reserves the right to negotiate, prior to award, as permitted by District Rules 137-049-0420 and 137-049-0430. Further, as additional grant funding is pending, District reserves the right to negotiate a change order with the chosen awardee for [additional area buildouts at one or more station sites]. Station drawings demonstrate potential additional buildout areas including: community area, sleeping quarters, and associated items.

# NOTICE OF INTENT TO AWARD

Southwestern Polk County Rural Fire Protection District  
Invitation to Bid

Rickreall Fire Station

Salt Creek Fire Station

Bridgeport Fire Station

To all Bidders:

Based on responses to the recent Invitation to Bid and other information obtained from third party sources, \_\_\_\_\_ has been identified as the lowest responsible, responsive bidder to contract with Southwestern Polk County Rural Fire Protection District for the above referenced Project(s). Protests regarding this intended award will be received by Fred Hertel, Fire Chief, Southwestern Polk County Rural Fire Protection District, PO Box 6 or 230 SW Mill Street, Sheridan, OR 97378, until March, 2020. Award will become final on March, 2020] or once the District responds to all timely filed protests and affirms the award, whichever is later.

It is the District's intent to begin negotiations and enter into a contract for these services with \_\_\_\_\_, by \_\_\_\_\_, 2020. The District would like to finalize the contract no later than March 30, 2020, with approval by the District Board on April 9, 2020. The contract terms, specifications and conditions were included with the ITB.

If you have any questions, please feel free to call me at \_\_\_\_\_.

Sincerely,

SOUTHWESTERN POLK COUNTY RURAL  
FIRE PROTECTION DISTRICT

By: \_\_\_\_\_

# BID FORM

Southwestern Polk County Rural Fire Protection District  
Station Construct Project (Project)  
Dallas, OR 97338

This bid is submitted to Southwestern Polk County Rural Fire Protection District, PO Box 6 or 230 SW Mill Street, Sheridan, OR 97378.

1. The undersigned bidder proposes and agrees, if this bid is accepted, to enter into a Construction Agreement with the District in the form included in the contract documents and to complete all work as specified or indicated in the contract documents for the contract price and within the contract time indicated in this bid and in accordance with the contract documents.
2. Bidder accepts all of the terms and conditions of the Instructions to Bidders, including without limitation, those dealing with disposition of bid security. This bid may not be amended or withdrawn and is subject to acceptance for forty (40) days after the date of bid opening. The successful bidder will sign the Construction Agreement included as part of the bid packet and submit the security and other documents required by the contract documents within ten (10) days after the date of District's Notice of Award.
3. In submitting this bid, bidder represents as more fully set forth in the Construction Agreement, that:

(a) Bidder has examined copies of the contract documents and the following addenda:

Date: _____	Number: _____
Date: _____	Number: _____
Date: _____	Number: _____
Date: _____	Number: _____

and also copies of the advertisement or Invitation to Bid and Instructions to Bidders;

- (b) Bidder has examined the site and locality where the Work is to be performed, the applicable legal requirements (federal, state, and local, ordinances, rules, and regulations) and the conditions affecting cost, progress, or performance of work, and has made such independent investigation as bidder deems necessary;
- (c) This bid is genuine and not made in the interest of or on behalf of any undisclosed person, firm, or corporation, and is not submitted in conformity with any agreement or rules of any group, association, organization, or corporation; bidder has not directly or indirectly induced or

solicited any other bidder to submit a false or sham bid; bidder has not solicited or induced any person, firm, or corporation to refrain from bidding; and bidder has not sought by collusion to obtain for himself any advantage over any other bidder or the District;

- (d) The District anticipates awarding at least one and potentially a total of three (3) station projects to one (1) contractor, but reserves the right to solicit additional bids and award project contracts to different contractors for one (1) or more stations, in District's sole discretion. The District does not have to award any contract based on the bids submitted. Any award which the District makes will be on the basis of the lowest responsible bidder.

4. Bid Quantities and Specifications	Unit Price	Total
_____	_____	_____
_____	_____	_____
_____	_____	_____

Bidder will complete all Projects for an aggregate total price of: \$\_\_\_\_\_. Bidder will complete each individual station Project for the following amounts:

Rickreall Fire Station      \$ \_\_\_\_\_  
 Salt Creek Fire Station    \$ \_\_\_\_\_  
 Bridgeport Fire Station    \$ \_\_\_\_\_

- 5. Bidder agrees to prepare the site and perform the labor necessary to complete all three construction Projects, which will be substantially completed in accordance with the plans and specifications attached hereto within \_\_\_\_\_ days of the receipt of the notice to proceed.

Bidder agrees to prepare the site and perform the labor necessary to complete individual construction Projects, which will be substantially completed in accordance with the plans and specifications attached hereto within the following number of days after receipt of the notice to proceed:

Rickreall Fire Station      \_\_\_\_\_ days  
 Salt Creek Fire Station    \_\_\_\_\_ days  
 Bridgeport Fire Station    \_\_\_\_\_ days

- 6. Bidder acknowledges that bidder has reviewed the provisions of the Construction Agreement as to liquidated damages which may be assessed in the event of failure to complete the Work on time and has considered those potential damages in formulating this bid.

7. The following documents are attached to and made a condition to the bid:
- (a) Required bid security in the form of a bid bond or certified check in the amount of 10% of the bid;
  - (b) Non-Collusion Affidavit;
  - (c) First Tier Subcontractor Disclosure Form (attached to the bid or submitted to the District within two (2) hours after bid closing).

8. Bidder agrees and certifies as follows:
- (a) The provisions of ORS 279C.800 *et seq.*, relating to the prevailing wage rates, will be complied with;
  - (b) Bidder is a resident of the State of \_\_\_\_\_ as defined in ORS 279A.120;
  - (c) The provisions of ORS 305.385 relating to Oregon tax laws will be complied with;
  - (d) Bidder has not and will not discriminate against minorities, women or emerging small business enterprises in obtaining any subcontracts required under this Contract, or against a business enterprise owner controlled by, or that employs, a disabled veteran as defined in ORS 408.225;
  - (e) All employers, including bidder, that employ subject workers who work under the Construction Agreement shall comply with ORS 656.017 and provide the required Workers' Compensation coverage unless such employers are exempt under ORS 656.126. Bidder shall ensure that each of its subcontractors complies with these requirements;
  - (f) Bidder is registered and in good standing with the Construction Contractors Board in accordance with ORS 701.035 to 701.055;
  - (g) All subcontractors performing work as described in ORS 701.005(2) will be registered with the Construction Contractors Board in accordance with ORS 701.035 to 701.055 before the subcontractors commence work under the contract.

9. Communications concerning this bid shall be addressed to:

Bidder: \_\_\_\_\_  
\_\_\_\_\_  
\_\_\_\_\_

Submitted this \_\_\_\_\_ day of \_\_\_\_\_, 2020.

\_\_\_\_\_  
(Corporate Name) (Company Name)  
(Corporate Seal, if any)

By: \_\_\_\_\_  
(Name of person authorized to  
Sign, or Title)

Business Address: \_\_\_\_\_

Phone: (\_\_\_\_) \_\_\_\_\_

State of Incorporation: \_\_\_\_\_

Oregon Contractor Board No.: \_\_\_\_\_

ATTEST:

\_\_\_\_\_  
Secretary of bidding corporation

DRAFT



# NOTICE OF AWARD

To: \_\_\_\_\_

PROJECT description: Southwestern Polk County  
Rural Fire Protection District (District)

Rickreall Fire Station

Salt Creek Fire Station

Bridgeport Fire Station

The District has considered the bid submitted by \_\_\_\_\_  
(Contractor) for the above described Project(s) in response to its advertisement for bids  
dated [weekday], \_\_\_\_\_, 2020, and Instructions to Bidders.

Contractor is hereby notified that its bid in the amount of \_\_\_\_\_  
\_\_\_\_\_ (amount in written form) (\$ \_\_\_\_\_) has  
been accepted by the District.

Contractor is required by the Instructions to Bidders to execute the Construction  
Agreement and furnish the required Contractor's Performance Bond, Payment Bond  
and certificates of insurance within ten (10) calendar days from the date of this notice.

If Contractor fails to execute the Construction Agreement and to furnish the required  
bonds and certificates of insurance within ten (10) days from the date of this notice,  
District will be entitled to consider all Contractor's rights arising out of District's  
acceptance of Contractor's bid as abandoned and as a forfeiture of Contractor's bid  
bond. District will be entitled to such other rights as may be granted by law.

Please return an acknowledged copy of this Notice to Award to District.

DATED this \_\_\_\_\_ day of \_\_\_\_\_, 2020.

SOUTHWESTERN POLK COUNTY  
RURAL FIRE PROTECTION DISTRICT

By: \_\_\_\_\_

\* \* \* \* \*

## ACCEPTANCE OF AWARD

Receipt of the above Notice of Award is hereby acknowledged by \_\_\_\_\_  
\_\_\_\_\_ on this \_\_\_\_\_ day of \_\_\_\_\_, 2020.

By: \_\_\_\_\_  
Title: \_\_\_\_\_

DRAFT

# NOTICE TO PROCEED

TO: \_\_\_\_\_

Date: \_\_\_\_\_

Southwestern Polk County Rural Fire Protection District (District)

Rickreall Fire Station

Salt Creek Fire Station

Bridgeport Fire Station

\_\_\_\_\_ (Contractor) is hereby notified to commence Project(s) in accordance with the Construction Agreement dated \_\_\_\_\_, 2020, on or before \_\_\_\_\_, 2020, and Contractor is to complete the Work on the Project within \_\_\_ consecutive calendar days thereafter. The date of final completion for all work is \_\_\_\_\_, 2020.

Please return an acknowledged copy of this Notice to Proceed to District.

SOUTHWESTERN POLK COUNTY  
RURAL FIRE PROTECTION DISTRICT

By: \_\_\_\_\_

\* \* \* \* \*

## ACCEPTANCE OF NOTICE TO PROCEED

Receipt of the above Notice to Proceed is hereby acknowledged by \_\_\_\_\_  
\_\_\_\_\_ on this \_\_\_\_\_ day of \_\_\_\_\_, 2020.

By: \_\_\_\_\_

Title: \_\_\_\_\_



Name of Company: \_\_\_\_\_  
Position: \_\_\_\_\_

SIGNED and SWORN to before me this \_\_\_\_\_ day of \_\_\_\_\_,  
2020, by \_\_\_\_\_.

Notary Public for \_\_\_\_\_

DRAFT

# FIRST-TIER SUBCONTRACTOR DISCLOSURE FORM

PROJECT NAME: Station Construction Project

BID #: \_\_\_\_\_

BID CLOSING: Date: \_\_\_\_\_

Time: \_\_\_\_\_

This form must be submitted at the location specified in the Invitation to Bid on the advertised bid closing date and within two working hours after the advertised bid closing time.

List below the name of each subcontractor that is required to be disclosed, the category of work that the subcontractor will be performing and the dollar value of the subcontract. Enter "NONE" if there are no subcontractors that need to be disclosed. (ATTACH ADDITIONAL SHEETS IF NEEDED.)

NAME	DOLLAR VALUE	CATEGORY OF WORK
1) _____	\$ _____	_____
2) _____	\$ _____	_____
3) _____	\$ _____	_____
4) _____	\$ _____	_____
5) _____	\$ _____	_____
6) _____	\$ _____	_____

FAILURE TO SUBMIT THIS FORM BY THE DISCLOSURE DEADLINE WILL RESULT IN A NON-RESPONSIVE BID. A NON-RESPONSIVE BID WILL NOT BE CONSIDERED FOR AWARD.

Form submitted by (bidder name): \_\_\_\_\_

Contact name: \_\_\_\_\_

Phone no.: \_\_\_\_\_

# BIDDER'S PERFORMANCE AND PAYMENT BOND STATEMENT

\_\_\_\_\_ (Contractor) is submitting a bid to Southwestern Polk County Rural Fire Protection District (District) pursuant to the District's advertisement for bids dated \_\_\_\_\_, \_\_\_\_\_, 2020.

Contractor certifies that, if it is awarded the contract, Contractor has the financial ability to obtain good and sufficient bonds in the forms attached, issued by a surety to the District, each in a sum equal to the amount of the bid providing for the faithful performance of the contract.

Contractor understands and agrees that if Contractor fails to provide either the required performance bond or payment bond, the District may reject the bid and the bid bond submitted with the bid may be forfeited.

The surety requested to issue the performance bond will be \_\_\_\_\_ (Surety Company). Contractor authorizes Surety Company to disclose any information to District concerning Contractor's ability to supply a performance bond in the amount of the contract.

The surety requested to issue the payment bond will be \_\_\_\_\_ (Surety Company). Contractor authorizes Surety Company to disclose any information to District concerning Contractor's ability to supply a payment bond in the amount of the contract.

\_\_\_\_\_  
(Name of Contractor)

By: \_\_\_\_\_

# PERFORMANCE BOND

KNOW ALL PERSONS BY THESE PRESENTS that

\_\_\_\_\_

(Name of Contractor)

\_\_\_\_\_

(Address of Contractor)

a \_\_\_\_\_ hereinafter called "PRINCIPAL", and  
(Corporation, Partnership, or Individual)

\_\_\_\_\_

(Name of Surety)

\_\_\_\_\_

(Address of Surety)

\_\_\_\_\_

(Oregon representative for service of process for Surety)

hereinafter called "SURETY", are held and firmly bound unto

Southwestern Polk County  
Rural Fire Protection District  
PO Box 6 or 230 SW Mill Street  
Sheridan, OR 97378

hereinafter called "OWNER", in the total amount of \_\_\_\_\_  
(insert here a sum  
\_\_\_\_\_ Dollars (\$) \_\_\_\_\_) for the  
equal to the contract price)

payment whereof PRINCIPAL and SURETY bind themselves, their heirs, executors,  
administrators, successors and assigns jointly and severally, firmly by these presents.

WHEREAS, the PRINCIPAL has by written agreement entered into a certain contract  
with the OWNER, dated the \_\_\_\_\_ day of \_\_\_\_\_, 20\_\_, a copy of which  
is hereto attached and made a part hereof and is hereinafter referred to as the Contract.  
Said Contract is for:

\_\_\_\_\_  
\_\_\_\_\_  
\_\_\_\_\_

NOW, THEREFORE:



1. The condition of this obligation is such that, if PRINCIPAL shall promptly and faithfully perform said Contract, then this obligation shall be null and void; otherwise it shall remain in full force and effect.

2. The SURETY hereby waives notice of any alteration or extension of time made by the OWNER.

3. It is expressly agreed that the Bond shall be deemed amended automatically and immediately, without formal and separate amendments hereto, upon amendment of the Contract, so as to bind the PRINCIPAL and the SURETY to the full and faithful performance of the Contract as so amended. The term "Amendment," wherever used in this Bond, and whether referring to this Bond, the Contract, or any Loan Documents shall include any alteration, addition, extension or modification of any character whatsoever.

4. Whenever PRINCIPAL shall be, and declared by OWNER to be in default under the Contract, the OWNER having performed OWNER's obligations thereunder, the SURETY may promptly remedy the default, or shall promptly:

a) Arrange for the PRINCIPAL, with consent of the OWNER, to perform and complete the contract;

b) Complete the Contract in accordance with its terms and conditions, or

c) Obtain a bid or bids for completing the Contract in accordance with its terms and conditions, and upon determination by OWNER and the SURETY jointly of the lowest responsible bidder, arrange for a contract between such bidder and OWNER, and make available as work progresses (even though there should be a default or a succession of defaults under the contract or contracts of completion arranged under this paragraph) sufficient funds to pay the cost of completion less the balance of the contract price; but not exceeding, including other costs and damages for which the SURETY may be liable hereunder, the amount set forth above. The term "balance of the contract price," as used in this paragraph, shall mean the total amount payable by OWNER to PRINCIPAL under the Contract and any amendments thereto, less the amount properly paid by OWNER to PRINCIPAL.

5. Any suit under this Bond must be instituted before the expiration of two (2) years from the date on which final payment under the Contract falls due.

6. If any provision of this Bond conflicts with state law, such portion will be deemed deleted therefrom and provisions conforming to such state law shall be deemed incorporated herein. The intent is that the bond shall be construed as a statutory bond and not as a common law bond.

7. No right of action shall accrue on this Bond to or for the use of any person or corporation other than the OWNER named herein or the heirs, executors, administrators or successors of the OWNER.

IN WITNESS WHEREOF, this instrument is executed in \_\_\_\_\_ counterparts, each one of which shall be deemed an original, this the \_\_\_\_\_ day of \_\_\_\_\_, 2020.

ATTEST:

\_\_\_\_\_  
PRINCIPAL

\_\_\_\_\_  
(PRINCIPAL) Secretary

(SEAL)

By: \_\_\_\_\_

\_\_\_\_\_  
(Witness to PRINCIPAL)

\_\_\_\_\_  
(Address)

\_\_\_\_\_  
(Address)

\_\_\_\_\_  
(SURETY)

ATTEST:

\_\_\_\_\_  
(Witness to SURETY)

By \_\_\_\_\_

(Attorney-in-Fact)

\_\_\_\_\_  
(Address)

\_\_\_\_\_  
(Address)

NOTE: Date of Bond must not be prior to date of Contract.

If CONTRACTOR is partnership, all partners must execute Bond.

IMPORTANT: SURETY companies executing BONDS must appear on the Treasury Department's most current list (Circular 570 as amended) and be authorized to transact business in Oregon. SURETY companies must also have an Oregon representative for service of process.

# PAYMENT BOND

Any singular reference to Contractor, Surety, Owner, or other party shall be considered plural where applicable.

CONTRACTOR (Name and Address):

\_\_\_\_\_  
\_\_\_\_\_  
\_\_\_\_\_

SURETY (Name and Address of  
Principal Place of Business):

\_\_\_\_\_  
\_\_\_\_\_  
\_\_\_\_\_

## CONTRACT

Effective Date of Agreement:

Amount:

Description (Name and Location):

\_\_\_\_\_  
\_\_\_\_\_  
\_\_\_\_\_  
\_\_\_\_\_  
\_\_\_\_\_

## BOND

Bond Number:

Date (Not earlier than Effective Date of Agreement):

Amount:

Modifications to this Bond Form:

\_\_\_\_\_  
\_\_\_\_\_  
\_\_\_\_\_

Surety and Contractor, intending to be legally bound hereby, subject to the terms set forth below, do each cause this Payment Bond to be duly executed by an authorized officer, agent, or representative.

CONTRACTOR AS PRINCIPAL

SURETY

\_\_\_\_\_  
Contractor's Name and Corporate Seal (Seal)

\_\_\_\_\_  
Surety's Name and Corporate Seal (Seal)

By: \_\_\_\_\_  
Signature

By: \_\_\_\_\_  
Signature (Attach Power of Attorney)

Print Name: \_\_\_\_\_

Print Name: \_\_\_\_\_

Title: \_\_\_\_\_

Title: \_\_\_\_\_

ATTEST: \_\_\_\_\_  
Signature

ATTEST: \_\_\_\_\_  
Signature

\_\_\_\_\_  
Title

\_\_\_\_\_  
Title

1. Contractor and Surety, jointly and severally, bind themselves, their heirs, executors, administrators, successors, and assigns to Owner to pay for labor, materials, and equipment furnished by Claimants for use in the performance of the Contract, which is incorporated herein by reference.

2. With respect to Owner, this obligation shall be null and void if Contractor:

2.1 Promptly makes payment, directly or indirectly, for all sums due Claimants, and

2.2 Defends, indemnifies, and holds harmless Owner from all claims, demands, liens, or suits alleging non-payment by Contractor by any person or entity who furnished labor, materials, or equipment for use in the performance of the Contract, provided Owner has promptly notified Contractor and Surety (at the addresses described in paragraph 12) of any claims, demands, liens, or suits and tendered defense of such claims, demands, liens, or suits to Contractor and Surety, and provided there is no Owner Default.

3. With respect to Claimants, this obligation shall be null and void if Contractor promptly makes payment, directly or indirectly, for all sums due.

4. Surety shall have no obligation to Claimants under this Bond until:

4.1 Claimants who are employed by or have a direct contract with Contractor have given notice to Surety (at the address described in paragraph 12) and sent a copy, or notice thereof, to Owner, stating that a claim is being made under this Bond and, with substantial accuracy, the amount of the claim.

4.2 Claimants who do not have a direct contract with Contractor:

1. Have furnished written notice to Contractor and sent a copy, or notice thereof, to Owner, within 90 days after having last performed labor or last furnished materials or equipment included in the claim stating, with substantial accuracy, the amount of the claim and the name of the party to whom the materials or equipment were furnished or supplied, or for whom the labor was done or performed; and

2. Have either received a rejection in whole or in part from Contractor, or not received within 30 days of furnishing the above notice any communication from Contractor by which Contractor indicated the claim will be paid directly or indirectly; and

3. Not having been paid within the above 30 days, have sent a written notice to Surety (at the address described in paragraph 12) and sent a copy, or notice thereof, to Owner, stating that a claim is being made under this Bond and enclosing a copy of the previous written notice furnished to Contractor.

5. If a notice by a Claimant required by paragraph 4 is provided by Owner to Contractor or to Surety, that is sufficient compliance.
6. Reserved.
7. Surety's total obligation shall not exceed the amount of this Bond, and the amount of this Bond shall be credited for any payments made in good faith by Surety.
8. Amounts owed by Owner to Contractor under the Contract shall be used for the performance of the Contract and to satisfy claims, if any, under any performance bond. By Contractor furnishing and Owner accepting this Bond, they agree that all funds earned by Contractor in the performance of the Contract are dedicated to satisfy obligations of Contractor and Surety under this Bond, subject to Owner's priority to use the funds for the completion of the Work.
9. Surety shall not be liable to Owner, Claimants, or others for obligations of Contractor that are unrelated to the Contract. Owner shall not be liable for payment of any costs or expenses of any Claimant under this Bond, and shall have under this Bond no obligations to make payments to, give notices on behalf of, or otherwise have obligations to Claimants under this Bond.
10. Surety hereby waives notice of any change, including changes of time, to the Contract or to related subcontracts, purchase orders, and other obligations.
11. No suit or action shall be commenced by a Claimant under this Bond other than in a court of competent jurisdiction in the location in which the Work or part of the Work is located or after the expiration of one year from the date (1) on which the Claimant gave the notice required by Paragraph 4.1 or Paragraph 4.2.3, or (2) on which the last labor or service was performed by anyone or the last materials or equipment were furnished by anyone under the Contract, whichever of (1) or (2) first occurs. If the provisions of this paragraph are void or prohibited by law, the minimum period of limitation available to sureties as a defense in the jurisdiction of the suit shall be applicable.
12. Notice to Surety, Owner, or Contractor shall be mailed or delivered to the addresses shown on the signature page. Actual receipt of notice by Surety, Owner, or Contractor, however accomplished shall be sufficient compliance as of the date received at the address shown on the signature page.
13. When this Bond has been furnished to comply with a statutory requirement in the location where the Contract was to be performed, any provision in this Bond conflicting with said statutory requirement shall be deemed deleted here from and provisions conforming to such statutory requirement shall be deemed incorporated herein. The intent is that this Bond shall be construed as a statutory Bond and not as a common law bond.

14. Upon request of any person or entity appearing to be a potential beneficiary of this Bond, Contractor shall promptly furnish a copy of this Bond or shall permit a copy to be made.

15. Definitions

15.1 Claimant: An individual or entity having a direct contract with Contractor, or with a first-tier subcontractor of Contractor, to furnish labor, materials, or equipment for use in the performance of the Contract. The intent of this Bond shall be to include without limitation in the terms "labor, materials or equipment" that part of water, gas, power, light, heat, oil, gasoline, telephone service, or rental equipment used in the Contract, architectural and engineering services required for performance of the Work of Contractor and Contractor's subcontractors, and all other items for which a mechanic's lien may be asserted in the jurisdiction where the labor, materials, or equipment were furnished.

15.2 Contract: The agreement between Owner and Contractor identified on the signature page, including all Contract Documents and changes thereto.

15.3 Owner Default: Failure of Owner, which has neither been remedied nor waived, to pay Contractor as required by the Contract, or to perform and complete or otherwise comply with the other terms thereof.

**FOR INFORMATION ONLY:**

Name, Address and Telephone:

---

---

---

Surety Agency or Broker:

Owner's Representative (Engineer or other):

---

---

# AGREEMENT

THIS AGREEMENT is made this \_\_\_\_\_ day of \_\_\_\_\_, 2020, by and between the Southwestern Polk County Rural Fire Protection District, hereinafter called Owner, and \_\_\_\_\_, hereinafter called Contractor, in consideration of mutual covenants hereinafter set forth, agree as follows:

1. **Work.** Contractor shall complete all work as specified in the contract documents and in accordance with the documents and drawings provided for the Project known as the Station Construction Project (Project).
2. **Materials.** Contractor will furnish all materials, supplies, tools, equipment, labor and other services necessary for the construction and completion of the Project described herein.
3. **Contract Time.** The Work will commence within ten (10) calendar days after the date of the Notice to Proceed and will be completed by the Contractor and accepted by the District no later than \_\_\_\_\_, 2020, unless the period for completion is extended otherwise by the contract documents or by written agreement of the parties.
4. **Contract Price.** Owner shall pay Contractor for performance of the Work in accordance with the documents the sum of \$\_\_\_\_\_ as shown in Contractor's bid.
5. **Liquidated Damages.** Owner and Contractor acknowledge and agree that if the Work is not completed by the contract time, the amount of Owner's actual loss of use damages will be difficult and impractical, or impossible to determine. Accordingly, the parties agree that if the Project is not completed by the agreed upon date, as adjusted pursuant to the contract documents, the Contractor shall pay \$100.00 to Owner, as liquidated damages for the loss of use of the Project.

The parties further acknowledge and agree that the daily sum for liquidated damages to be paid, as set forth above, is reasonable and that the payment of such liquidated damages is not intended to nor constitutes a penalty or forfeiture. The parties further acknowledge that these liquidated damages are meant to reimburse the Owner only for loss of use delay damages and that Owner reserves the right to claim other types of damages against Contractor including but not limited to actual delay damages.

6. **Progress Payments.** Owner shall make progress payments on the basis of the Contractor's application for payment as approved by the Owner's representative on or about the last day of each month during construction as provided herein. All progress payments shall be on the basis of progress of the Work measured by the schedule of values provided for in Section 19 of the General Conditions. Prior to substantial completion, progress payments will be an amount equal to not more than 95% of the Work completed and 95% of the materials and

equipment not incorporated in the Work, but delivered and suitably stored, less in each case the aggregate of payments previously made. Upon substantial completion, the Owner shall pay an amount sufficient to increase total payments to Contractor to 95% of the contract price, less such amounts as the Owner shall determine in accordance with Section 19 of the General Conditions. Final payment shall be upon final completion and acceptance of the Work. Approved partial payment estimates shall be reviewed and approved at the next regularly scheduled Board meeting.

**7. Contract Documents.** The term "contract documents" means and includes the following:

- (a) Invitation to Bid;
- (b) Instructions to Bidders;
- (c) Bid;
- (d) Bid Bond;
- (e) Construction Agreement;
- (f) First-Tier Subcontractor Disclosure Form
- (g) Oregon Prevailing Wage Rates;
- (h) General Conditions;
- (i) Payment Bond;
- (j) Performance Bond;
- (k) Notice of Intent to Award;
- (l) Notice to Proceed;
- (m) Drawings and Specifications attached;
- (n) Change Orders;
- (o) Addenda; Number: \_\_\_\_\_ Dated: \_\_\_\_\_
- (p) Proof of Insurance

**8. Contractor's Representations.** In order to induce Owner to enter into this agreement, Contractor makes the following representations:

- (a) Contractor has familiarized itself with the nature and extent of the contract documents, work, locality, and with all local conditions and any federal, state, and local laws, ordinances, rules, and regulations which, in any manner, may affect cost, progress, or performance of the Work;
- (b) Contractor has studied carefully all reports, investigations, and tests of subsurface and latent physical conditions at the site which may affect cost, progress, or performance of work and which were relied upon in the preparation of the drawings and specifications;
- (c) Contractor has made or has caused to be made examinations, investigations, tests and studies of reports and related data, in addition to those referred to in paragraph (b), which Contractor deems necessary for the performance of the Work, determination of the contract price, and completion of the Project within the contract time in accordance with the other terms and conditions of the contract documents. No additional



examinations, investigations, tests, reports, or similar data are or will be required by Contractor for such purposes;

- (d) Contractor has reconciled the results of all such observations, examinations, investigations, tests, reports, and data with the terms and conditions of the contract documents;
- (e) Contractor has given the Owner's representative written notice of all conflicts, errors or discrepancies which he has discovered in the contract documents and the written resolution thereof by the Owner's representative is acceptable to the Contractor.

**9. Miscellaneous.**

- (a) No assignment by a party hereto of any rights under or interests in the contract documents will be binding on another party to this contract without the written consent of the parties sought to be bound; and specifically but without limitation, monies which may become due and monies which are due may not be assigned without such consent (except to the extent that the effect of this restriction may be limited by law) and unless specifically stated to the contrary in any written consent to an assignment, no assignment will release or discharge the assignor from any duty or responsibility under the contract documents.
- (b) This Agreement shall be binding upon all parties to the contract and their respective partners, successor, heirs, assigns, and legal representatives in respect to all covenants, agreements, and obligations contained in the contractual documents.

THIS AGREEMENT is effective on the \_\_\_\_\_ day of \_\_\_\_\_, 2020.

OWNER:

CONTRACTOR:

By: \_\_\_\_\_

By: \_\_\_\_\_

Address for giving notices:

Address for giving notices:

\_\_\_\_\_  
\_\_\_\_\_

\_\_\_\_\_  
\_\_\_\_\_

ATTEST:

ATTEST:

\_\_\_\_\_

\_\_\_\_\_  
Agent for Service of Process  
License # \_\_\_\_\_

# GENERAL CONDITIONS

**Section 1. Definitions.** Whenever used in these General Conditions or in the other contract documents, the following terms have the meanings indicated which are applicable in both the singular and plural or masculine or feminine thereof:

1. **Addenda.** Written or graphic instruments issued prior to the execution of the Agreement which modify or interpret the contract documents, Drawings and specifications by additions, deletions, clarifications, or corrections.
2. **Bid.** The offer or proposal of the bidder submitted on the prescribed form setting forth the prices for the Work to be performed.
3. **Bonds.** Bid, performance and payment bonds and other instruments of security.
4. **Change Order.** A written order to the Contractor signed by the Owner authorizing an addition, deletion or revision in the Work, or an adjustment in the contract price or the contract time issued after the effective date of the Agreement.
5. **Contract Price.** The total monies payable to the Contractor under the terms and conditions of the contract documents.
6. **Contract Time.** The number of calendar days stated in the contract documents for completion of the Work.
7. **Contractor.** The person, firm, or corporation with whom the Owner has executed the Agreement.
8. **Drawings.** The part of the contract documents which show the characteristics and scope of the Work to be performed and are referred to in the contract documents.
9. **Owner's Representative.** That person appointed by the Board of Directors of the Owner to act as the Owner's Representative in all matters relating to this contract.
10. **Field Order.** A written order issued by the Owner's Representative which orders minor changes in Work not involving an adjustment in the contract price or an extension of the contract time.
11. **Substantial Completion.** The date certified by the Owner's Representative when the construction of the Project or a specified part thereof is sufficiently completed in accordance with the contract documents so that the Project or a specified part can be utilized for purposes for which it is intended.

12. Subcontractor. An individual, firm, or corporation having a direct contract with the Contractor or with any other Subcontractor for the performance of a part of the Work at the site.
13. Supplier. Any person or organization who supplies materials or equipment for the Work, including that fabricated to a special design but who does not perform labor at the site.
14. Work. All labor necessary to produce the construction required by the contract documents and all materials and equipment incorporated or to be incorporated in the Project.
15. Written Notice. Any notice to any party to the Agreement, or relative to any part of this Agreement, in writing is considered delivered and service completed when posted by certified mail or registered mail to the party at the party's last given address as shown on the Agreement, or when delivered in person to the party or the party's authorized representative on the worksite.

## **Section 2. Preliminary Matters.**

1. Delivery of Bonds. When the Contractor delivers the executed Contract Documents to the Owner, Contractor shall also deliver to Owner such bonds as the Contractor may be required to furnish.
2. Copies of Documents. Owner shall furnish to Contractor up to three (3) copies of the contract documents. Additional copies will be furnished upon request at the cost of reproduction.
3. Commencement of Contract Time. The contract time will commence to run on the day indicated in the Notice to Proceed.
4. Insurance. Before undertaking any Work on the Project, Contractor shall obtain and, during the life of this Agreement, Contractor shall maintain the following minimum public liability and property damage insurance naming the Owner as an additional insured, which shall protect the Owner and the Contractor from claims for injuries, including accidental death, as well as from claims for property damage which may arise out of or result from Contractor's performance of the Work and Contractor's other obligations under the Contract Documents whether such performance is by Contractor or any Subcontractor, or by anyone directly or indirectly employed by any of them, or by anyone for whose acts any of them may be liable:
  - (a) Commercial general liability insurance, including personal injury liability, blanket contractual liability and broad form property damage liability. The combined single limit for bodily injury and property damage shall not be less than \$2,000,000.
  - (b) Statutory workers' compensation and employer's liability insurance for the State of Oregon.

Contractor shall provide the Owner with certificates of insurance before undertaking any Work on the Project. Insurance policies shall not be amended, canceled or terminated without 30-days prior written notice to the Owner.

5. Owner Insurance. The Owner shall be responsible for purchasing and maintaining its own liability insurance. Owner shall also purchase and maintain property insurance upon the Work at the site to the full insurable value thereof and shall include the interest of the Owner, Contractor and Subcontractors in the Work against the perils of fire and extended coverage. All other risk of loss at the Work site shall be borne by Contractor until acceptance of building by Owner.
6. Subrogation Waiver. Owner and Contractor **waive** all rights against each other, their agents and any Subcontractors and their agents and employees for damages caused by fire or other perils to the extent covered by insurance provided for in this Section. The Contractor shall require similar written waivers from each Subcontractor and each such waiver shall be in favor of all other parties enumerated in this paragraph.

### **Section 3. Contract Documents.**

1. The contract documents **comprise** the entire **agreement** between Owner and Contractor concerning the Work. **They** may be altered only by written modification, as provided in this Agreement.
2. The contract documents are **complementary**; what is called for by one is binding as if called for by all. If, during the **performance** of the Work, Contractor finds a conflict, error or **discrepancy** in the contract documents, Contractor shall report it to the **Owner's Representative** in writing at once and before proceeding with the Work affected by the conflict.
3. It is the intent of the specifications and Drawings to describe the complete Project to be **constructed** in accordance with the contract documents. Any Work which may reasonably be inferred from the specifications or Drawings as being required to produce the intended result shall be supplied whether or not it is specifically called for. **When** words which have a well-known technical or trade meaning are used to describe Work, materials, or equipment, such words shall be interpreted in accordance with such meaning. Reference to standard specifications, manuals, or codes of any technical society, organization, or association, or to the code of any governmental authority, whether such reference be specific or by implication, shall mean the latest standard, specification, manual or code in effect at the time of the opening of the bid, except as may be otherwise specifically stated. However, no provision of any reference, standard, specification, manual or code shall change the duties and responsibilities of the Owner, Contractor, or any of their agents or employees from those set forth in the contract documents. Clarifications and interpretations of the contract documents shall be issued by the Owner's Representative.

4. Re-use of Documents. Neither Contractor nor any Subcontractor, manufacturer, fabricator, Supplier, or distributor shall have or acquire any title to or ownership rights in any of the Drawings, specifications, or other documents which are a part of this contract. They may not be reused by any party without the express written consent of the Owner and of the preparer of the Drawings.

#### **Section 4. Materials, Service and Facilities.**

1. It is understood that, except as otherwise specifically stated in the contract documents, the Contractor shall provide and pay for all materials, labor, tools, equipment, water, lights, power, transportation, supervision, temporary construction of any nature, and all other services and facilities of any nature whatsoever necessary to execute, complete, and deliver the Work within the specified time.
2. Materials and equipment shall be stored so as to ensure the preservation of their quality and fitness for the Work. Stored materials and equipment to be incorporated in the Work shall be located so as to facilitate prompt inspection. All materials and equipment shall be applied, installed, connected, erected, used, cleaned and conditioned as directed by the manufacturer.
3. All materials and equipment shall be of good quality and new except as otherwise provided in the contract documents.
4. Equivalent Materials and Equipment. Whenever materials or equipment are specified or described in Drawings or specifications by using the name of proprietary item or the name of a particular manufacturer, fabricator, Supplier or distributor, the name of the item is intended to establish the type, function and quality required. Unless the name is followed by words indicating that no substitution is permitted, materials or equipment of other manufacturers, fabricators, Suppliers, or distributors may be accepted by the Owner's Representative if sufficient information is submitted by Contractor to allow the Owner's Representative to determine that the material proposed is equivalent to that named.
5. Contractor shall be fully responsible for all acts and omissions of its Subcontractors and of persons and organizations directly or indirectly employed by Contractor and any Subcontractor and of persons or organizations for whose acts any of them may be liable to the same extent Contractor is responsible for the acts and omissions of persons directly employed by Contractor. Nothing in these documents creates any obligation on the part of the Owner to pay or to see to the payment of any monies due any Subcontractor or other person or organization except as may otherwise be required by law.

## **Section 5. Fees, Taxes and Permits.**

1. Contractor shall pay all applicable royalties and license fees. Contractor shall defend all suits or claims for infringement of any patent rights and save Owner harmless from loss on account thereof.
2. All permits and licenses required for construction shall be obtained at the expense of Contractor. Owner shall assist the Contractor when necessary in obtaining such permits and licenses. Contractor shall pay all governmental charges and inspection fees necessary for the prosecution of the Work and which are applicable at the time of Bid opening. Contractor shall pay all charges of utility service companies for connections to the Work. Contractor shall pay all sales, consumer, use and other similar taxes required to be paid by Contractor in accordance with the laws of the place of the Project.

## **Section 6. Survey, Permits and Regulations.**

1. Owner shall furnish all boundary surveys and establish all base lines for locating principal component parts of the Work together with a suitable number of bench marks adjacent to the Work as shown in the contract documents. From the information provided by Owner, unless otherwise specified in the contract documents, Contractor shall develop and make all detailed surveys needed for construction such as slope stakes, stakes for piling locations, and other working points, lines, elevations and cut sheets.
2. The Contractor shall carefully preserve bench marks, reference points and stakes and, in case of willful or careless destruction, Contractor shall be charged with the resulting expense and shall be responsible for any mistakes which may be caused by unnecessary loss or disturbance.

## **Section 7. Protection of Work, Property and Persons.**

Contractor will be responsible for initiating, maintaining and supervising all safety precautions and programs in connection with the Work. Contractor will take all necessary precautions for the safety of, or provide the necessary protection to prevent injury, damage, or loss, to all employees on the worksite and other persons who may be affected. Contractor shall also be responsible for all safety precautions regarding all Work and all materials or equipment to be incorporated into the Work, whether in storage on or off the site, and the property at the site or adjacent to it, including trees, shrubs, lawns, walks, pavements, roadways, structures, and utilities not designed for removal, relocation, or replacement in the course of construction. Contractor will remedy all damage, injury or loss to any property caused, directly or indirectly, in whole or in part, by the Contractor, any Subcontractor, or anyone directly or indirectly employed by any of them or any for whose acts any of them may be liable except for acts directly attributable to Owner or Owner's Representative or any person employed by either of them whose acts are not attributable directly or indirectly in whole or in part to the fault or negligence of Contractor.

## **Section 8. Supervision by Contractor.**

The Contractor will supervise and direct the Work. Contractor will be solely responsible for the means, methods, techniques, sequences, and procedures of construction. Contractor will employ and maintain on the Work a qualified supervisor who shall have been designated in writing by Contractor as Contractor's representative at the site. The supervisor shall have full authority to act on behalf of Contractor and all communications given to the supervisor shall be as binding as if given to Contractor. The supervisor shall be present on the site at all times as required to perform adequate supervision and coordination of the Work.

## **Section 9. Changes in Work.**

Owner, at any time the need arises, may order changes in the scope of the Work without invalidating the Agreement. If such changes increase or decrease the amount due under the contract documents, or the time required for performance of the Work, an equitable adjustment shall be authorized by Change Order. Owner or its representative may also, at any time, by issuing a Field Order, make changes in the details of the Work. Contractor shall proceed with the performance of any changes in the Work so ordered, unless Contractor believes that such Field Order entitles Contractor to a change in Contract Price or Contract Time, or both, in which event Contractor shall give Owner's Representative Written Notice of the proposed Change Order within two (2) days after receipt of the Field Order. Contractor shall document in Contractor's notice the basis for the change in Contract Price or Contract Time by separate notice delivered within five (5) days of the date of the Written Notice of the proposed Change Order. Contractor shall not execute such changes pending the receipt of an executed Change Order or further instruction from Owner.

## **Section 10. Changes in Contract Price.**

The Contract Price may be changed only by a written, signed Change Order setting forth the agreed upon Change in Work, and any corresponding Contract Price increase or deduction, the value of which shall be determined by one or more of the following methods in the order of precedence listed below:

1. Unit pricing may be utilized at the Owner's option when unit prices or solicitation alternates were provided that established the cost for additional Work, and a binding obligation exists under the Contract on the parties covering the terms and conditions of the additional Work.
2. If the Owner elects not to utilize unit pricing, or in the event that unit pricing is not available or appropriate, fixed pricing may be used for Change Order Work. In fixed pricing the basis of payments or total price shall be agreed upon in writing between the parties to the Contract, and shall be established before the Work is done whenever feasible. The mark-ups set forth in D.1.3(c) shall be utilized by the parties as a guide in establishing fixed pricing, and will not be exceeded by Owner without adequate justification. Cost and price data relating to Change

Orders shall be supplied by Contractor to Owner upon request, but Owner shall be under no obligation to make such requests.

3. In the event that unit pricing and fixed pricing are not utilized, then Change Order Work shall be performed on a cost reimbursement basis for Direct Costs. Such Work shall be compensated on the basis of the actual, reasonable and allowable cost of labor, equipment, and material furnished on the Work performed. In addition, the following markups shall be added to the Contractor's or Subcontractor's Direct Costs as full compensation for profit, Overhead and other indirect costs for Work directly performed with the Contractor's or Subcontractor's own forces:

On Labor.....	10%
On Equipment.....	10%
On Materials.....	10%

When Change Order Work under Section 10(3) is invoiced by an authorized Subcontractor at any level, ascending tiers of Subcontractor or Contractor will not be allowed any supplemental mark-up on each piece of subcontract Work covered by such Change Order.

Payments made to the Contractor shall be complete compensation for Overhead, profit, and all costs that were incurred by the Contractor or by other forces furnished by the Contractor, including Subcontractors, for Change Order Work. Owner may establish a maximum cost for Change Order Work under this Section 10(3), which shall not be exceeded for reimbursement without additional written authorization from Owner. Contractor shall not be required to complete such Change Order Work without additional authorization.

### **Section 11. Limitation on Liquidated Damages.**

Contractor shall not be charged with liquidated damages when the delay in completion of the Work is due to the following and Contractor has promptly given Written Notice of such delay to Owner or its representative:

1. Unforeseeable causes beyond the control and without the fault or negligence of Contractor, including but not restricted to acts of God or of the public enemy, acts of Owner, acts of another Contractor in performance of the contract with the Owner, fires, floods, epidemics, quarantine restriction, strikes, freight embargoes, and abnormal and unforeseen weather; and
2. Any delays of Subcontractors occasioned by any of the causes specified above.

### **Section 12. Correction of Work.**

1. Contractor shall promptly remove from the premises all Work rejected by Owner's Representative for failure to comply with the contract documents, whether incorporated in construction or not, and Contractor shall promptly



replace and re execute the Work in accordance with the contract documents and without expense to Owner and shall bear the expense of making good all Work of other contractors destroyed or damaged by such removal or replacement.

2. All removal and replacement Work shall be done at Contractor's expense. If Contractor does not take action to remove rejected Work within five (5) days after receipt of Written Notice of rejection, Owner may remove such Work and store the materials at the expense of Contractor.

### **Section 13. Subsurface Conditions.**

Contractor shall promptly and before such conditions are disturbed, except in the event of an emergency, notify Owner by Written Notice of:

1. Subsurface or latent physical conditions at the site differing materially from those indicated in the contract documents.
2. Unknown physical conditions at the site of an unusual nature, differing markedly from those ordinarily encountered and generally recognized as inherent in Work of the character provided for in the contract.

Owner shall promptly investigate the conditions and if found that such conditions do so materially differ and cause an increase or decrease in the cost of or in the time required for performance of the Work, an equitable adjustment shall be made and the contract documents shall be modified by a change order. Any claim of Contractor for adjustment hereunder shall not be allowed unless he has given the required Written Notice.

### **Section 14. Suspension of Work, Termination Delay.**

1. If Contractor is adjudged a bankrupt or insolvent or if Contractor makes a general assignment for the benefit of Contractor's creditors, or if a trustee or receiver is appointed for the Contractor or for any of Contractor's property, or if Contractor files a petition to take advantage of any debtor's act or to reorganize under bankruptcy or applicable laws, or if Contractor repeatedly fails to supply sufficient skilled workmen or suitable material or equipment, or if Contractor repeatedly fails to make prompt payments to Subcontractors for labor, materials, or equipment, or if Contractor disregards laws, ordinances, rules, regulations, or orders of any public body having jurisdiction of the Work, or if Contractor disregards the authority of Owner's Representative or if Contractor otherwise violates any provision of the contract documents, then Owner may, without prejudice to any other right or remedy, after giving Contractor and Contractor's surety a minimum of five (5) days' Written Notice, terminate the services of the Contractor and take possession of the Project and all materials, equipment, tools, construction equipment, and machinery owned by Contractor and finish the Work by whatever method Owner may deem expedient. In such case, Contractor shall not be entitled to receive any further payment until the Work is finished. If the unpaid balance of the contract price exceeds the direct and indirect costs of completing the Project, including compensation for additional professional

services, such excess shall be paid to Contractor. If the costs exceed such unpaid balances, Contractor will pay the difference to Owner. Such costs incurred by Owner will be determined by Owner and incorporated in a change order.

2. Where Contractor's services have been terminated under Section 14.1, by Owner, the termination shall not affect any right of Owner against Contractor then existing or which may thereafter accrue. Any retention or payment of monies by Owner due Contractor will not release Contractor from compliance with the contract documents.
3. After five (5) days from delivery of Written Notice under Section 14.1 to Contractor, Owner may, without cause and without prejudice to any other right or remedy, elect to abandon the Project and terminate the contract. In such case, Contractor shall be paid for all Work executed and any reasonable expense sustained plus reasonable profit for the Work performed.

#### **Section 15. Equal Opportunity.**

Contractor agrees to comply with the applicable provisions of the Equal Opportunity Act of 1972 and the Civil Rights Act of 1964 as amended. Contractor shall have the obligation to ensure that the employees and applicants for employment are not discriminated against because of race, creed, color, sex, or national origin.

#### **Section 16. Public Contracting Code Requirements.**

1. Contractor shall pay promptly, as due, all persons supplying labor or materials for the prosecution of the Work provided for in the contract, and shall be responsible for such payment of all persons supplying such labor or material to any Subcontractor.
  - (a) ORS 279C.580(3)(a) requires the prime Contractor to include a clause in each subcontract requiring Contractor to pay the first-tier Subcontractor for satisfactory performance under its subcontract within ten (10) days out of such amounts as are paid to the prime Contractor by the public contracting agency; and
  - (b) ORS 279C.580(3)(b) requires the prime Contractor to include a clause in each subcontract requiring Contractor to pay an interest penalty to the first-tier Subcontractor if payment is not made within thirty (30) days after receipt of payment from the public contracting agency.
  - (c) ORS 279C.580(4) requires the prime Contractor to include in every subcontract a requirement that the payment and interest penalty clauses required by ORS 279C.580(3)(a) and (b) be included in every contract between a Subcontractor and a lower-tier Subcontractor or Supplier.

2. Contractor shall promptly pay all contributions or amounts due the Industrial Accident Fund from such Contractor or Subcontractor incurred in the performance of the contract, and shall be responsible that all sums due the State Unemployment Compensation Fund from Contractor or any Subcontractor in connection with the performance of the contract shall promptly be paid.
3. Contractor shall not permit any lien or claim to be filed or prosecuted against the Owner on account of any labor or material furnished and agrees to assume responsibility for satisfaction of any such lien so filed or prosecuted.
4. A notice of claim on Contractor's payment bond shall be submitted only in accordance with ORS 279C.600 and 279C.605.
5. Contractor and any Subcontractor shall pay to the Department of Revenue all sums withheld from employees pursuant to ORS 316.167.
6. Contractor shall demonstrate to Owner that an employee drug-testing program is in place within ten (10) days of receiving a Notice of Award.
7. Pursuant to ORS 279C.515, if Contractor fails, neglects or refuses to make prompt payment of any claim for labor or materials furnished to the Contractor or a Subcontractor by any person in connection with the contract as such claim becomes due, the Owner may pay such claim to the persons furnishing the labor or material and charge the amount of payment against funds due or to become due to Contractor by reason of the contract. The payment of a claim in the manner authorized hereby shall not relieve the Contractor or its surety from their obligations with respect to any unpaid claim. If Owner is unable to determine the validity of any claim for labor or material furnished, Owner may withhold from any current payment due Contractor an amount equal to said claim until its validity is determined and the claim, if valid, is paid.
8. Pursuant to ORS 279C.515, if the Contractor or a first-tier Subcontractor fails, neglects, or refuses to make payment to a person furnishing labor or materials in connection with the public contract for a public improvement within 30 days after receipt of payment from Owner or Contractor, the Contractor or first-tier Subcontractor shall owe the person the amount due plus interest charges commencing at the end of the 10 day period that payment is due under ORS 279C.580(4) and ending upon final payment, unless payment is subject to a good faith dispute as defined in ORS 279C.580. The rate of interest charged to Contractor or first-tier Subcontractor on the amount due shall equal three times the discount rate on 90-day commercial paper in effect at the Federal Reserve Bank in the Federal Reserve District that includes Oregon on the date that is thirty (30) days after the date when payment was received from the public contracting agency or from the Contractor, but the rate of interest shall not exceed thirty (30) percent. The amount of interest may not be waived.
9. As provided in ORS 279C.515, if the Contractor or a Subcontractor fails, neglects, or refuses to make payment to a person furnishing labor or materials in

connection with the public contract, the person may file a complaint with the Construction Contractors Board, unless payment is subject to a good faith dispute as defined in ORS 279C.580.

10. ORS 279C.527 (Green Energy Technology): Contractor shall ensure Owner's compliance with all applicable provisions of ORS 279C.527 and OAR Chapter 330 Division 135 regarding green energy technology requirements for new or major renovations of public buildings costing over \$5,000,000.
11. Pursuant to ORS 279C.530, Contractor shall promptly, as due, make payment to any person, co-partnership, association, or corporation, furnishing medical, surgical and hospital care or other needed care and attention, incident to sickness or injury, to employees of such Contractor, of all sums which the Contractor agrees to pay for such services and all monies and sums which the Contractor collected or deducted from the wages of employees pursuant to any law, contract or agreement for the purpose of providing or paying for such service.
12. Contractor shall employ no person for more than ten (10) hours in any one day, or forty (40) hours in any one week, except in cases of necessity, emergency, or where public policy absolutely requires it, and in such cases, except in cases of contracts for personal services designated under ORS 279A.055, Contractor shall pay the employee at least time and one-half pay for all overtime in excess of eight (8) hours a day or forty (40) hours in any one week when the Work is five (5) consecutive days, Monday through Friday; or for all overtime in excess of ten (10) hours a day or forty (40) hours in any one week when the Work week is 4 consecutive days, Monday through Friday; and for all Work performed on Saturday and on any legal holidays as specified in ORS 279C.540.
13. Pursuant to ORS 279C.540(2), the Contractor must give notice to employees who Work on this contract in writing, either at the time of hire or before commencement of Work on the contract, or by posting a notice in a location frequented by employees, of the number of hours per day and the days per week that the employees may be required to Work.
14. The provisions of ORS 279C.800 to ORS 279C.870 relating to the prevailing wage rates will be complied with. The hourly rate of wage to be paid by Contractor or any Subcontractor to workers in each trade or occupation required for the public works employed in the performance of this Contract shall not be less than the specified minimum rate of wage in accordance with ORS 279C.838 and ORS 279C.840.
  - (a) The latest prevailing wage rates for public works contracts in Oregon are contained in the following publications: The January 1,2020, Prevailing Wage Rates for Public Works Projects in Oregon, including any Amendments. Such publication can be reviewed electronically at:

<https://www.oregon.gov/boli/WHD/PWR/Pages/PWR-Rate-Publications---2020.aspx>

and are hereby incorporated as part of the contract documents.

- (b) Contractor and all Subcontractors shall keep the prevailing wage rates for this Project posted in a conspicuous and accessible place in or about the Project.
  - (c) The Owner shall pay a fee to the Commissioner of the Oregon Bureau of Labor and Industries as provided in ORS 279C.825. The fee shall be paid to the Commissioner as required by the administrative rules adopted by the Commissioner.
  - (d) If Contractor or any Subcontractor also provides for or contributes to a health and welfare plan or a pension plan, or both, for its employees on the Project, it shall post notice describing such plans in a conspicuous and accessible place in or about the Project. The notice shall contain information on how and where to make claims and where to obtain future information.
15. Unless exempt under ORS 279C.836(4), (7), (8) or (9), before starting Work on this contract, or any subcontract hereunder, Contractor and all Subcontractors must have on file with the Construction Contractors Board a public works bond with a corporate surety authorized to do business in the State of Oregon in the amount of \$30,000. The bond must provide that the Contractor or Subcontractor will pay claims ordered by the Bureau of Labor and Industries to workers performing labor upon public works projects. The bond must be a continuing obligation, and the surety's liability for the aggregate of claims that may be payable from the bond may not exceed the penal sum of the bond. The bond must remain in effect continuously until depleted by claims paid under ORS 279C.836(2), unless the surety sooner cancels the bond. The surety may cancel the bond by giving thirty (30) days' Written Notice to the Contractor or Subcontractor, to the Construction Contractors Board and to the Bureau of Labor and Industries. When the bond is canceled, the surety is relieved of further liability for Work performed on contracts entered into after the cancellation. The cancellation does not limit the surety's liability for Work performed on contracts entered into before the cancellation. Contractor further certifies that Contractor will include in every subcontract a provision requiring a Subcontractor to file a public works bond with the Construction Contractors Board before starting Work on the Project, unless exempt under ORS 279C.836(4), (7), (8), or (9).
- (a) Unless exempt under ORS 279C.836(4), (7), (8), or (9), before permitting a Subcontractor to start Work on this public works project, the Contractor shall verify that the Subcontractor has filed a public works bond as required under this section or has elected not to file a public works bond under ORS 279C.836(7).
  - (b) Unless the Owner has been notified of any applicable exemptions under ORS 279C.836(4), (7), (8), or (9), the public works bond requirement above is in addition to any other bond Contractor or Subcontractors may be required to obtain under this contract.

16. As may be required by ORS 279C.845, Contractor or Contractor's surety and every Subcontractor or Subcontractor's surety shall file certified payroll statements with the Owner in writing.
  - (a) If Contractor is required to file certified statements under ORS 279C.845, the Owner shall retain twenty-five (25) percent of any amount earned by the Contractor on the public works project until the Contractor has filed with the Owner a certified statement as required by ORS 279C.845. The Owner shall pay the Contractor the amount retained within 14 days after the Contractor files the required certified statements, regardless of whether a Subcontractor has failed to file certified statements required by statute. The Owner is not required to verify the truth of the contents of certified statements filed by the Contractor under this section and ORS 279C.845.
  - (b) The Contractor shall retain twenty-five (25) percent of any amount earned by a first-tier Subcontractor on this public works contract until the Subcontractor has filed with the Owner certified statements as required by ORS 279C.845. The Contractor shall verify that the first-tier Subcontractor has filed the certified statements before the Contractor may pay the Subcontractor any amount retained. The Contractor shall pay the first-tier Subcontractor the amount retained within fourteen (14) days after the Subcontractor files the certified statements as required by ORS 279C.845. Neither the Owner nor the Contractor is required to verify the truth of the contents of certified statements filed by a first-tier Subcontractor.
17. All employers, including Contractor, that employ subject workers who Work under this contract shall comply with ORS 656.017 and provide the required Workers' Compensation coverage, unless such employers are exempt under ORS 656.126. Contractor shall ensure that each of its Subcontractors complies with these requirements.
18. All sums due the State Unemployment Compensation Fund from the Contractor or any Subcontractor in connection with the performance of the contract shall be promptly so paid.
19. The contract may be canceled at the election of Owner for any willful failure on the part of Contractor to faithfully perform the contract according to its terms.
20. Contractor certifies that it has not and will not discriminate against minorities, women or emerging small business enterprises in obtaining any required Subcontractors, or against a business enterprise that is owned or controlled by, or that employs a disabled veteran as defined in ORS 408.225.
21. Contractor certifies its compliance with the Oregon tax laws, in accordance with ORS 305.385.

22. In the performance of this contract, the Contractor shall use, to the maximum extent economically feasible, recycled paper, materials, and supplies, and shall compost or mulch yard waste material at an approved site, if feasible and cost effective.
23. As may be applicable, Contractor certifies that all Subcontractors performing construction Work under this contract will be registered with the Construction Contractors Board or licensed by the state Landscaping Contractors Board in accordance with ORS 701.035 to ORS 701.055 before the Subcontractors commence Work under this contract.
24. Pursuant to District Rule 137-049-0880, the Owner may, at reasonable times and places, have access to and an opportunity to inspect, examine, copy, and audit the records relating to the Contract.
25. Pursuant to ORS 279C.510, if feasible and cost-effective and contract is for demolition, Contractor shall salvage or recycle construction and demolition debris.
26. Pursuant to ORS 279C.510, if feasible and cost-effective and contract is for lawn and landscape maintenance, Contractor shall compost or mulch yard waste material at an approved site.
27. In compliance with the provisions of ORS 279C.525, the following is a list of federal, state and local agencies, of which the Owner has knowledge, that have enacted ordinances or regulations dealing with the prevention of environmental pollution and the preservation of natural resources that may affect the performance of the contract:

**FEDERAL AGENCIES:**

- Agriculture, Department of
  - Forest Service
  - Soil Conservation Service
- Defense, Department of
  - Army Corps of Engineers
- Environmental Protection Agency
- Interior, Department of
  - Bureau of Sport Fisheries and Wildlife
  - Bureau of Outdoor Recreation
  - Bureau of Land Management
  - Bureau of Indian Affairs
  - Bureau of Reclamation
- Labor, Department of
  - Occupational Safety and Health Administration
- Transportation, Department of
  - Federal Highway Administration
- Homeland Security, Department of

- Coast Guard

STATE AGENCIES:

- Agriculture, Department of
- Environmental Quality, Department of
- Fish and Wildlife, Department of
- Forestry, Department of
- Geology and Mineral Industries, Department of
- Human Resources, Department of
- Land Conservation and Development Commission
- Soil and Water Conservation Commission
- State Engineer
- State Land Board
- Water Resources Board

LOCAL AGENCIES:

- City Council
- County Court
- County Commissioners, Board of
- Port Districts
- Metropolitan Service Districts
- County Service Districts
- Sanitary Districts
- Water Districts
- Fire Protection Districts

28. Once before the first payment and once before final payment is made of any sum due on account of the contract for a public work, Contractor or Contractor's surety and every Subcontractor with a Subcontractor's surety, shall file a statement with Owner in writing in the form prescribed by the Commissioner of the Bureau of Labor and Industries, certifying the hourly rate of wage paid each classification of worker which Contractor or Subcontractor has employed upon such public work, and further certifying that no worker employed upon such public work has been paid less than the prevailing rate of wage or less than the minimum hourly rate of wage specified in the contract, which certificate and statement shall be verified by the oath of Contractor or Contractor's surety or Subcontractor or the Subcontractor's surety, that Contractor or Subcontractor has read such statement and certificate, knows the contents thereof, and that the same is true to Contractor's or Subcontractor's knowledge. A true copy of the certification or certifications required to be filed pursuant to this section shall also be filed at the same time with the Commissioner of the Bureau of Labor and Industries.
29. The following notice is applicable to Work involving excavation. "ATTENTION: Oregon law requires you to follow rules adopted by the Oregon Utility Notification



Center. Those rules are set forth in OAR 952-001-0010 through OAR 952-001-0090. You may obtain copies of the rules by calling the center at (503) 232-1987.”

## **Section 17. Warranty and Guarantee.**

1. Contractor warrants and guarantees to Owner that all Work will be done in accordance with the Contract Documents and will not be defective. Prompt notice of all defects shall be given to Contractor. All defective Work, whether or not in place, may be rejected, corrected or accepted. Contractor understands that the City of Dallas and Polk County and their various departments, and agencies, must be consulted and be allowed to inspect the Work and sign off in each particular area. At all times Owner’s Representative and appropriate inspectors shall have access to the Work for inspection and testing. Contractor shall provide proper and safe conditions for such access.
2. Where any law, ordinance, rule, regulation, code, or other order of any public body having jurisdiction requires any Work or part thereof to specifically inspected, tested or approved, Contractor shall assume full responsibility for such inspection, testing, or approval, and pay all costs in connection therewith and furnish Owner’s Representative with the required certificates of inspection, testing or approval. If any Work to be inspected, tested, or approved is covered without written concurrence of Owner’s Representative, it must be, if requested, uncovered for observation. Such uncovering shall be at Contractor’s expense.
3. Neither observations by the Owner’s Representative nor inspection tests or approvals by others shall relieve the Contractor from his obligations to perform the Work in accordance with the contract documents.
4. If, within two (2) years after the date of final completion and sign off and payment of any retainage by Owner to Contractor, there is any defect in materials or workmanship, Contractor shall promptly, without cost to Owner and in accordance with Owner’s written instructions, either correct such defective Work or, if it has been rejected by Owner, remove it from the site and replace it with non-defective Work. If Contractor does not promptly comply with the terms of such instructions, or in an emergency where a delay would cause serious risk of loss or damage, Owner may have the defective Work corrected or the rejected Work removed and replaced. All direct or indirect costs of such removal or replacement, including compensation for additional professional services, shall be paid by Contractor. Such additional professional services include the services of any attorney employed by Owner to assist it in dealings with Contractor. If Contractor does not pay for such Work, or does not ensure that such Work is performed as required by this section, Owner may pursue reimbursement from Contractor, including pursuing a claim upon Contractor’s bond, if applicable, for payment of such Work. All notices sent to Contractor shall have copies sent to Contractor’s surety.

5. Contractor warrants and guarantees that title to all Work, materials, and equipment covered by the application for payment, whether incorporated in the Project or not, will pass to Owner at the time of payment, free and clear of all liens, claims, security interests and encumbrances of any party whomsoever.

### **Section 18. Bond Form.**

Payment and Performance Bonds shall be in the form provided within the Invitation to Bid packet. Bid Bonds shall be in the standard form of the issuing company. If a standard form is not available, the AIA Form A-310 shall be acceptable for the Bid Bond.

### **Section 19. Payments to Contractor.**

1. By the 5th day of each month, Contractor will submit to Owner's Representative a partial payment estimate filled out and signed by Contractor covering the Work performed during the period covered by the partial payment estimate and supported by such data as Owner's Representative may reasonably require. If payment is requested on the basis of materials and equipment not incorporated in the Work but delivered and suitably stored at or near the site, the partial payment estimate shall also be accompanied by such supporting data, satisfactory to Owner, as will establish Owner's title to the material and equipment, and protect its interest therein, including applicable insurance. Owner's Representative will, within ten (10) days after receipt of each partial payment estimate, either indicate in writing his approval of payment and present the partial payment estimate to Owner, or return the partial payment estimate to Contractor indicating in writing his reasons for refusing to approve payment. In the latter case, Contractor may make the necessary corrections and resubmit the partial payment estimate. Owner will, within ten (10) days of the next Board meeting after presentation by Owner's Representative of an approved partial payment estimate, pay Contractor a progress payment on the basis of the approved partial payment estimate. Owner shall retain five percent (5%) of the amount of each payment until final completion and acceptance of all Work covered by the contract documents. After fifty percent (50%) of the Work has been completed, Owner may, at Owner's sole discretion, reduce or eliminate retainage on the remaining progress estimates. When the Work is substantially complete, Owner may, at Owner's sole discretion, further reduce the retained amount below 5% to only that amount necessary to assure completion. On completion and acceptance of a part of the Work on which the price is stated separately in the contract documents, Owner may, in Owner's sole discretion, pay for that part of the Work in full, including retained percentages, less authorized deductions.
2. A request for payment may also include an allowance for the cost of such major materials and equipment which are suitably stored either at or near the site.
3. Prior to Substantial Completion, Owner, with the approval of Owner's Representative and with the concurrence of the Contractor, may use any

completed or substantially completed portions of the Work. Such use shall not constitute an acceptance of such portions of the Work.

4. Owner shall have the right to enter the premises for the purpose of doing Work not covered by the contract documents. This provision shall not be construed as relieving Contractor of the sole responsibility for the care and protection of the Work, or the restoration of any damaged Work except such as may be caused by agents or employees of Owner. Such entry or Work shall only be allowed to the extent it does not interfere with Contractor's Work.
5. Upon completion and acceptance of the Work, Owner's Representative shall issue a certificate attached to the final payment request that the Work has been accepted by him under the conditions of the contract documents. The entire balance found to be due the Contractor, including the retained percentages, but except such sums as may be lawfully retained by Owner, shall be paid to the Contractor within thirty (30) days of the issuance of the certificate of completion and acceptance of the Work.
6. Contractor will indemnify and save Owner and Owner's officials, employees, agents, and volunteers harmless from all claims arising out of the lawful demands of Subcontractors, laborers, workmen, mechanics, materialmen, and furnishers or machinery and parts thereof, equipment, tools, and all supplies, incurred in the furtherance of the performance of the Work. Contractor shall, at Owner's request, furnish satisfactory evidence that all obligations of the nature designated above have been paid, discharged or waived. If Contractor fails to do so, Owner may, after having notified Contractor, either pay unpaid bills or withhold from Contractor's unpaid compensation a sum of money deemed reasonably sufficient to pay any and all such lawful claims until satisfactory evidence is furnished that all liabilities have been fully discharged whereupon payment to Contractor shall be resumed in accordance with the terms of the contract documents, but in no event shall the provisions of this Section be construed to impose any obligations upon Owner to either Contractor, Contractor's surety or any third party. In paying any unpaid bills of Contractor, any payment so made by Owner shall be considered as a payment made under the contract documents by Owner to Contractor and Owner shall not be liable to Contractor for any such payments made in good faith.
7. If Owner fails to make payment thirty (30) days after approval of a partial payment estimate by Owner's Representative, in addition to the other remedies available to Contractor, there shall be added to each such payment interest at the maximum legal rate commencing on the first day after said payment is due and continuing until the payment is received by the Contractor.

## **Section 20. Cleanup.**

1. From time to time as the Work progresses and immediately after completion of the Work, Contractor shall clean up and remove all refuse and unused materials of any kind resulting from the Work. Upon failure of Contractor to do so within

24 hours after being so directed by Owner's Representative, the Work may be done by Owner and the cost thereof may be deducted from any payment due Contractor.

2. After all other Work embraced in the contract is completed and before final acceptance of the contract, the entire right of way and driveways, alleys, and side street approaches, slopes, ditches, utility trenches, and construction areas shall be neatly finished to the lines, grades and cross sections shown in the specifications.
3. As a condition precedent to final acceptance of the Project, Contractor shall remove all equipment and temporary structures, and all rubbish, waste and generally clean the right of way and premises.

### **Section 21. Use of Light, Power and Water.**

Contractor shall furnish temporary light, power, and water complete with connecting piping, wiring, lamps, and similar equipment necessary before the Work is improved. Contractor shall install, maintain and remove temporary lines upon completion of Work. Contractor shall obtain all permits and bear all costs for connection with temporary services and facilities at no expense to Owner.

### **Section 22. Arbitration.**

1. All claims, disputes, and other matters in question between Owner and Contractor arising out of, or relating to, the contract documents, including rescission, reformation, enforcement, or the breach of the terms thereof, except for claims which may have been waived by the making or acceptance of final payment or for acquisition of property subject to eminent domain, may be decided by arbitration. Owner shall have the sole discretion as to whether or not a dispute will be decided by arbitration conducted in Polk County, Oregon, rather than through the court process.
2. No demand for arbitration of any claimed dispute or other matter shall be effective until after a claim or demand regarding the underlying dispute is made to the District's Board and the Board at its next regularly scheduled meeting, has rendered a written decision with respect thereto denying the claim or demand. No demand for arbitration of the denial of any such claim, dispute, or other matter shall be made later than thirty (30) days after the date on which the Board of Directors has rendered a written decision denying the claim. The failure to demand arbitration within thirty (30) days of the date of the Board of Director's decision denying the claim shall result in the Board of Director's decision being binding upon Owner and Contractor.
3. Notice of demand for arbitration shall be filed in writing with the other party to the agreement. The demand for arbitration shall be made within the 30 day period specified above. Owner, if not the party demanding arbitration, has the option of allowing the matter to proceed with arbitration or by Written Notice within five (5)

days after receipt of a demand for arbitration, or rejecting arbitration and requiring Contractor to proceed through the courts for relief. Arbitration shall be conducted under the Uniform Arbitration Act, ORS 36.600 *et seq.* If the parties are unable to mutually select an arbitrator within twenty (20) days following Owner's decision to pursue arbitration, then each party shall select an arbitrator, and the two arbitrators shall select a single arbitrator. The arbitrator(s) shall have substantial experience in construction disputes. The parties agree that any award rendered by the arbitrator will be final, and judgment may be entered upon the award in any court having jurisdiction thereof, and will not be subject to modification or appeal except to the extent permitted by Oregon law.

### **Section 23. Attorney Fees.**

If suit, action or arbitration is brought either directly or indirectly to rescind or enforce the terms of this agreement, the prevailing party shall recover and the losing party hereby agrees to pay reasonable attorney's fees incurred in such proceeding, in both the trial and appellate courts, as well as any costs and disbursements. Further, if it becomes necessary for Owner to incur the services of an attorney to enforce any provision of this agreement without initiating litigation, Contractor agrees to pay Owner's attorney's fees so incurred. Such costs and fees shall bear interest at the maximum legal rate from the date incurred, until the date paid by losing party.

DRAFT







DOOR MARK	SIZE		TYPE	FRAME				RATING (F)	HDW. (H)	REMARKS (R)
	W	H		FINISH (F)	GLASS (G)	COMPT. (C)	FINISH (F)			
101A	2'-0 1/2"	7'-0 3/4"	A	INCL	MS	HS	MS	2, 7, 12 / A-201	1	
101B	13'-0 1/4"	6'-0"	B	OP	PF	TSB		4, 8, 14 / A-201		
101C	13'-0 1/4"	6'-0"	B	OP	PF	TSB		4, 8, 14 / A-201		
101D	13'-0 1/4"	6'-0"	B	OP	PF	TSB		4, 8, 14 / A-201		
102A	2'-0 1/2"	6'-0 3/4"	C	INCL	MS	HS	MS	11, 18 / A-201	2	
102A*	2'-0 1/2"	6'-0 3/4"	E	INCL	MS	HS	MS	11, 18 / A-201	2	
102B	3'-0 1/2"	6'-0 3/4"	E	SC	WT	HS	MS	11, 18 / A-201	2	
102A*	3'-0 1/2"	6'-0 3/4"	A	SC	WT	HS	MS	11, 18 / A-201	2	
102B*	3'-0 1/2"	6'-0 3/4"	E	INCL	MS	HS	MS	11, 18 / A-201	2	
102A*	3'-0 1/2"	6'-0 3/4"	C	SC	WT	HS	MS	11, 18 / A-201	4	
102B*	3'-0 1/2"	6'-0 3/4"	D	SC	WT	HS	MS	11, 18 / A-201	5	1
102B	3'-0 1/2"	6'-0 3/4"	A	SC	WT	HS	MS	11, 18 / A-201	5	1
102B*	3'-0 1/2"	6'-0 3/4"	B	SC	WT	HS	MS	11, 18 / A-201	5	7
110A	3'-0 1/2"	6'-0 3/4"	B	INCL	MS	HS	MS	11, 18 / A-201	1	
110A*	3'-0 1/2"	6'-0 3/4"	B	INCL	MS	HS	MS	2, 7, 12 / A-201	1	
110C	4'-0 1/2"	6'-0 3/4"	A	INCL	MS	HS	MS	2, 7, 12 / A-201	1	

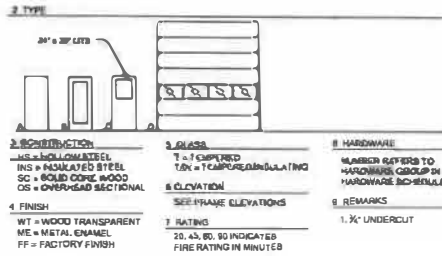

**GENERAL NOTES**

1. EXTERIOR WALLS: METAL SIDING, R-3 THERMAL SPACER BLOCK, 1/2" STEEL WALL BRIS WITH R-25 BATT INSUL. & VAPOR RETARDER
2. INTERIOR WALLS: 2 1/2" STU STUD @ 16" OC W/ ACUSTIC INSUL. LIN. SEE 18 & 19 / A-201 FOR ACUSTIC WALL DETAILS
3. FURNITURE IS TO BE CHLORUM
4. COFFER LIGHT / FIXTURES BY ROOM OR SPACE, LHM

**CONSTRUCTION NOTES**

1. 2" STU STUD @ 24" OC W/ R-21 BATT INSUL.
1. 1/2" INCH FIRE BARRIER, SEE DET. 1 / G-02
1. WALL FURRING: 3/4" STU STUD @ 24" OC W/ 1/2" GYP SO
1. WALL FURRING: 1 1/2" NAT OSB @ 24" OC W/ 1/2" GYP SO
1. FUTURE PLUMBING FUTURE
1. FUTURE PLUMBING FUTURE
1. FUTURE WASH/DRYER
1. 4" HIGH CONCRETE FLOORING AND UNDER WASHES
1. 18" WIDE DOUBLE-HIGH METAL LOCKERS, OPEN
1. TOWEL HOOK
1. SHOWER CURTAIN AND ROD
1. 1 1/2" STU STUD @ 24" OC W/ R-13 BATT INSUL.

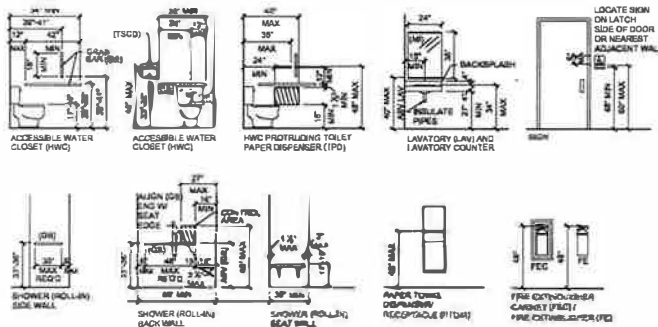
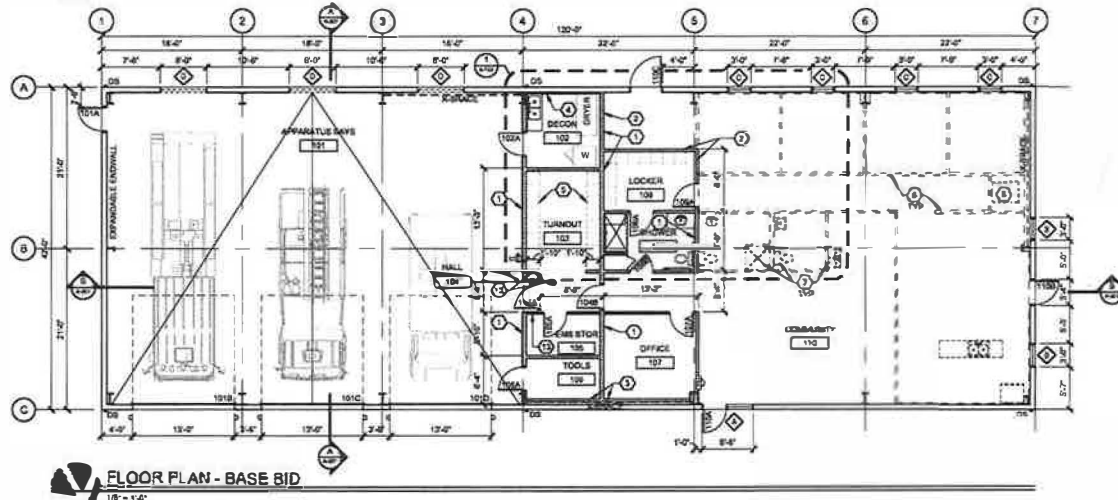
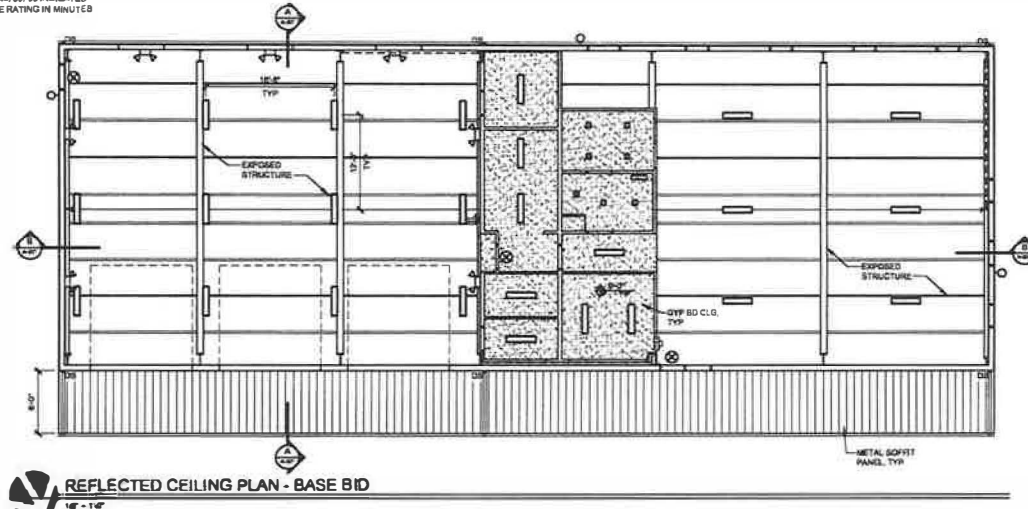
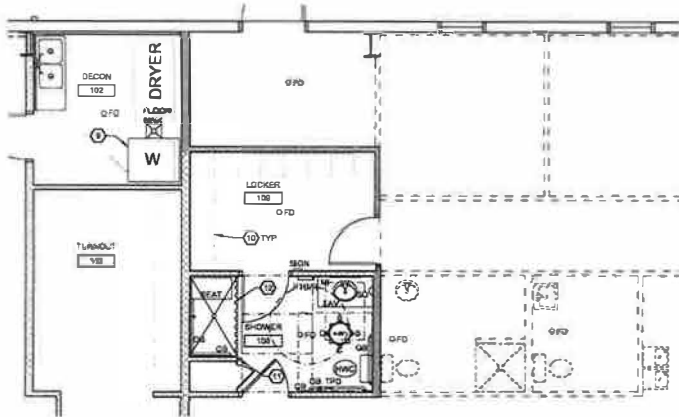

NTS  
 TYPICAL UNLESS OTHERWISE NOTED  
 ALL DIMENSIONS ARE CLEAR FINISH



PRELIMINARY  
 NOT FOR CONSTRUCTION  
 PRELIMINARY DATE  
 02-06-2020

SW POLK FIRE DISTRICT  
 SALT CREEK STATION  
 1000 W. 10TH AVE.  
 DALLAS, TX 75203

DATE: 07/018  
 PROJECT: A-102-X-07/018  
 DRAWN BY: NW  
 CHECKED BY:  
 COPYRIGHT © 2000  
 Carlson Veit Junge Architects P  
**FLOOR PLANS & DOOR SCHEDULE**

sheet:  
**A-102**

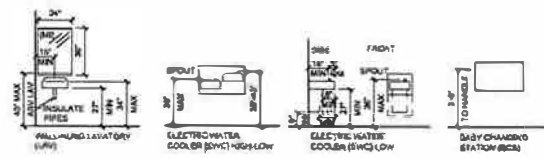

**FIXTURE MOUNTING HEIGHTS - ADD ALTERNATE #1**  
 TYPICAL UNLESS OTHERWISE NOTED  
 ALL DIMENSIONS ARE CLEAR FINISH

DOOR MARK	SIZE W X H X THK	DOOR				FRAME				HANGING		REMARKS (R)
		TYPE	FINISH	COLORS	COLORS	FINISH	ELEV. DTLS	TYPE	TYPE			
111A	2'-0"0" X 2'-3 1/2" X 3/4"	A	BD	WT	-	1H8	ME	11.18	A	81	1	
112A	3'-0"0" X 2'-3 1/2" X 3/4"	B	1H8	ME	18	1H8	ME	11.18	A	81	1	
112B	3'-0"0" X 2'-3 1/2" X 3/4"	C	1H8	ME	18	1H8	ME	11.18	A	81	1	
112C	3'-0"0" X 2'-3 1/2" X 3/4"	A	BD	WT	-	1H8	ME	11.18	A	81	1	
112D	4'-0"0" X 2'-3 1/2" X 3/4"	B	1H8	FF	-	1H8	ME	11.18	A	81	1	

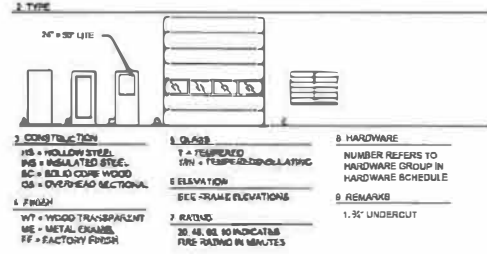

APPLIANCE SCHEDULE					
APPLIANCE	LOCATION	MANUFACTURER	MODEL	FINISH	NOTES
BREAK	BREAK 112	BOBCH	800 SERIES 30" FREE STANDING FRENCH DOOR REFRIGERATOR	STAINLESS STEEL	OPCL PROVIDE WATER HOOD-KAP FOR ICE AND WATER DISPENSER
OVN	BREAK 112	BERCH	800 SERIES 30" BUILT-IN HAND-CL. SPECIAL APPLICATION CONVECTION SLEDSHIM RANGE	STAINLESS STEEL	OPCL ADA COMPLIANT
RANGE	BREAK 112	BOBCH	800 SERIES 30" ELECTRIC SLEDSHIM RANGE	STAINLESS STEEL	OPCL ADA COMPLIANT FRONT CONTROLS
HOOD	BREAK 112	BOBCH	318 SERIES 30" UNDER CABINET HOOD	STAINLESS STEEL	OPCL LOCATE CONTROLS IN DRAWER BLANK TO THE RIGHT OF RANGE

- GENERAL NOTES**
- EXTERIOR WALLS: METAL SOING, 4-3 THERMAL SPACER BLOCK, 2" STEEL WALL GIRTS W/ 4-25 BATT INSUL. & VAPOR RETARDER
  - INTERIOR WALLS: 3 1/2" STL STUDS @ 16" OC W/ ACUSTIC INSUL. CON. SEE 18 & 19 / A-011 FOR ACUSTIC WALL DETAILS
  - FURNITURE IS TO BE ODFI UON
  - CEILING LIGHT FIXTURES BY ROOM OR SPACE UON

- CONSTRUCTION NOTES**
- 2" STL STUDS @ 24" OC W/ 1/2" BATT INSUL
  - 1-HOUR FIRE BARRIER, SEE DTL. 1 / G-022
  - WALL FURNING: 3 1/2" STL STUDS @ 24" OC W/ 1/2" GYP BD
  - WALL FURNING: 1 1/2" HAT CHANNELS @ 24" OC W/ 1/2" GYP BD
  - TURNOUT CLEAR COMPARTMENTS - ODFI PROVIDE BACKING FOR WALL MOUNTING
  - FUTURE WALL
  - FUTURE PLUMBING FEATURE
  - FUTURE WASH-HEARDRYER

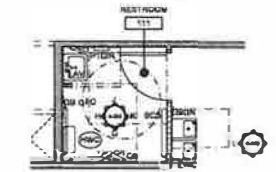

**1 LARGE SCALE FLOOR PLAN**  
 1/4" = 1'-0"

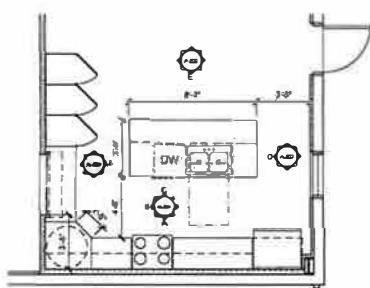

**2 LARGE SCALE FLOOR PLAN**  
 1/4" = 1'-0"

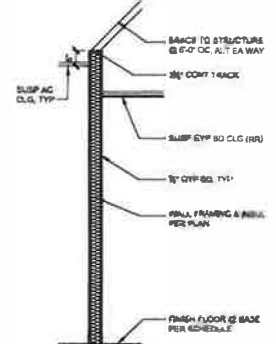

**3 TYP INT WALL SECTION**  
 1/4" = 1'-0"

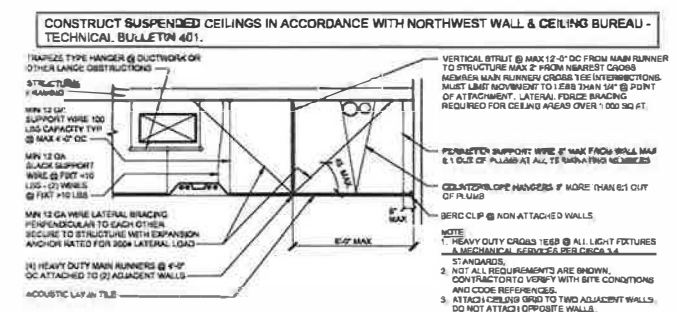

**4 SUSPENDED CEILING DETAIL**  
 1/4" = 1'-0"

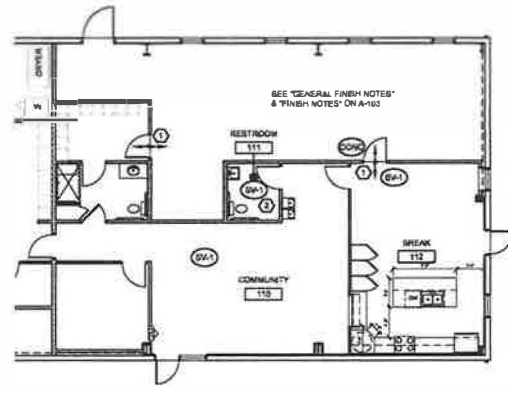

**FINISH PLAN - ADD ALTERNATE #1**  
 1/4" = 1'-0"

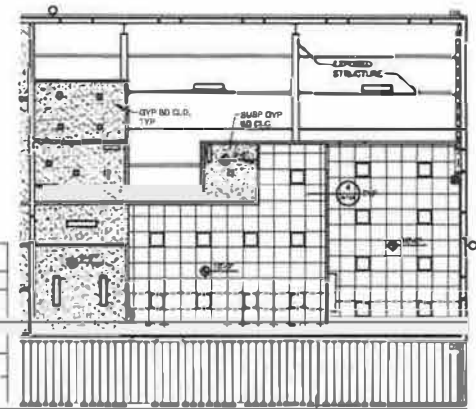

**REFLECTED CEILING PLAN - ADD ALTERNATE #1**  
 1/4" = 1'-0"

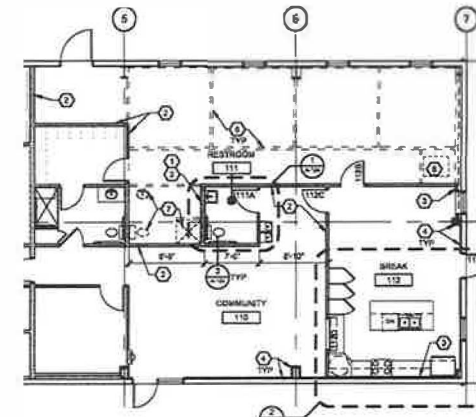

**FLOOR PLAN - ADD ALTERNATE #1**  
 1/4" = 1'-0"



**PRELIMINARY**  
 NOT FOR CONSTRUCTION  
 PRELIMINARY DATE  
**02-06-2020**

SW POLK FIRE DISTRICT  
 SALT CREEK STATION  
 1045 SALT CREEK ROAD  
 DALLAS, TX 75238

DATE: 07018  
 PROJECT: A-102X-07018  
 DRAWN BY: JMW  
 CHECKED BY: JMW  
 DESIGNED BY: JMW  
 PROJECT MANAGER: JMW  
**ADD ALTERNATE #1 - PLANS & DOOR SCHEDULE**  
 SHEET: **A-104**

WINDOW SCHEDULE						
W/M MARK	OPERATION	TYPE	GLASS	FRAME	FINISH	REMARKS (G)
A	F	MS	MC	I	FSH	C
B	F	V	FF	I	W	E
C	C	V	FF	I	PE	E
D	C	V	FF	I	W	E

- A. OPERATION TYPE**  
 F = FIXED  
 C = CASSETTE  
 S = SLIDING
- B. FRAME MATERIAL**  
 MS = MILD STEEL  
 V = VINYL  
 AL = ALUMINUM
- C. FRAME FINISH**  
 MS = METAL BRUSH  
 FF = FACTORY FINISH
- D. GLASS THICKNESS**  
 NUMBER REFERS TO OVERALL GLAZING UNIT THICKNESS
- E. GLASS TYPE**  
 T = TEMPERED  
 IN = INSULATING  
 TAN = TEMPERED INSULATING
- F. GLASS COLOR**  
 C = CLEAR  
 E = LOW-E COATED
- G. REMARKS**  
 WINDOW NOTES & GENERAL INFORMATION

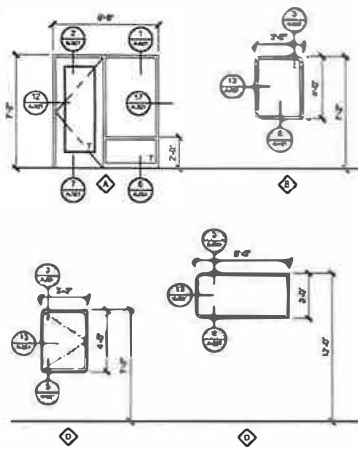

**WINDOW ELEVATIONS**

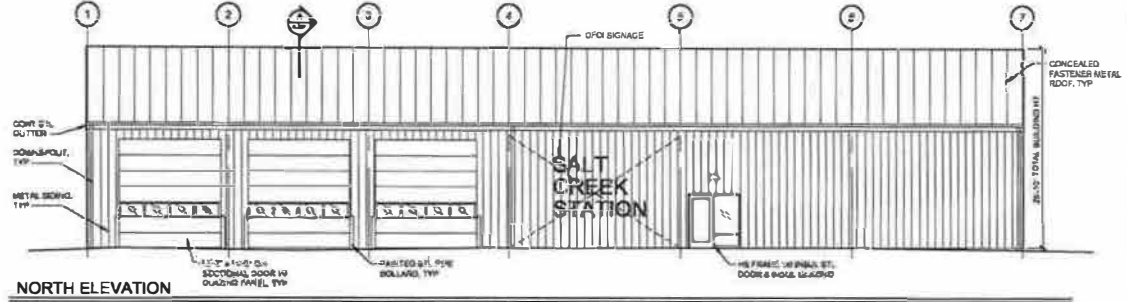

**NORTH ELEVATION**

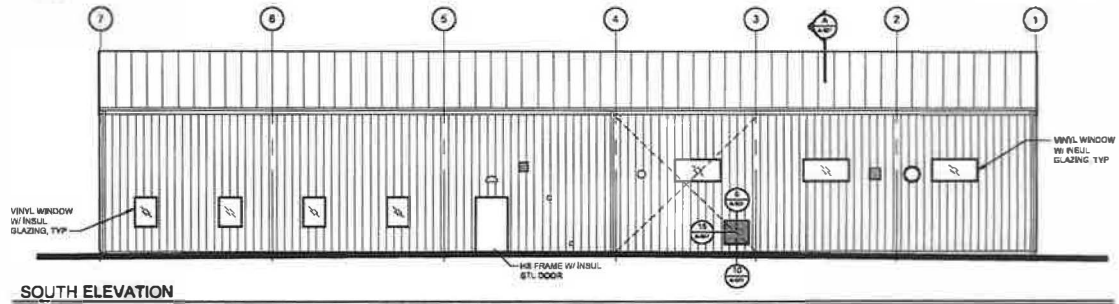

**SOUTH ELEVATION**

EXTERIOR FINISH SCHEDULE		
	APPROVED MANUFACTURERS	COLOR
ROOF	TAYLOR METAL PRODUCTS AEP SPAN	SIERRA TAN
METAL SIDING	TAYLOR METAL PRODUCTS AEP SPAN	SIERRA TAN
EAVES/SAKE TRIM, GUTTERS & DOWNSPOUTS	TAYLOR METAL PRODUCTS AEP SPAN	MUSKET
INSUL. STL. DOORS & MS FRAMES		PAINT TO MATCH TRIM, GUTTERS & DOWNSPOUTS
VINYL WINDOWS	MELGARD	ESPRESSO
PIPE BOLLARDS		PAINT SW 888

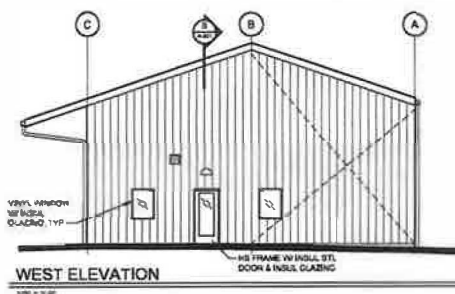

**WEST ELEVATION**

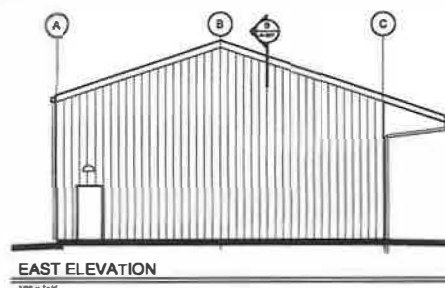

**EAST ELEVATION**

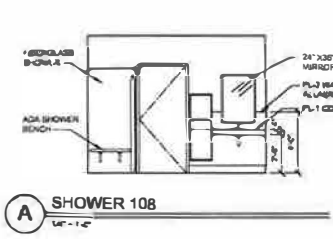

**A SHOWER 108**

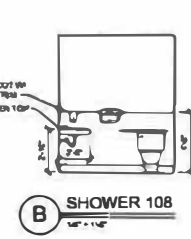

**B SHOWER 108**

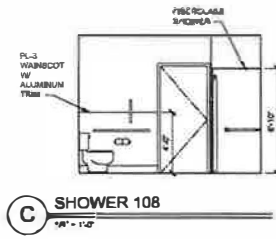

**C SHOWER 108**

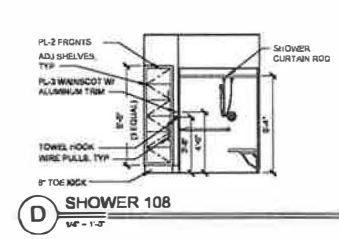

**D SHOWER 108**

CARLSON  
VEIT  
JUNGE  
ARCHITECTS PC

PRELIMINARY  
NOT FOR CONSTRUCTION

PRELIMINARY DATE:  
**02-06-2020**

PROJECT  
SW POLK FIRE DISTRICT  
SALT CREEK STATION  
15455 SW 11TH AVE  
DESIGN NO. 171243

DATE: 07/18  
 DWG FILE: A\_201X-07018  
 DRAWN BY: NWJ  
 CHECKED BY:  
 COPYRIGHT © 2020  
 Carlson Veit Junge Architects P  
**BUILDING, WINDOW  
& INTERIOR  
ELEVATIONS**

**A-201**

# SW POLK FIRE DISTRICT RICKREALL STATION

CARLSON  
VEIT  
JUNGE  
ARCHITECTS PC  
REGISTERED ARCHITECTS  
1325 LIBERTY STREET SE  
SALEM, OREGON 97302  
PHONE: (503) 394-4207

PRELIMINARY  
NOT FOR CONSTRUCTION

PRELIMINARY DATE:  
**02-06-2020**

SW POLK FIRE DISTRICT  
RICKREALL STATION  
3833 RICKREALL ROAD  
RICKREALL, OR 97137

Project: 02819  
Drawn by: G-001-X-02819  
Drawn by: NW  
Checked by:  
Copyright © 2020  
Carlson Veit Jungo Architects P.C.

TITLE SHEET  
G-001



## SYMBOLS / LEGEND

(NOT ALL ITEMS MAY BE USED IN THESE DRAWINGS)

	STEEL STUD WALL		FIRE EXTINGUISHER CABINET		DETAIL NUMBER
	FIRE-RATED WALL		ROOM NAME		SHEET NO. WHERE DRAWN
	NEW DOOR & DOOR MARK		ROOM FINISH SYMBOL		VIEW OF ELEVATION
	WINDOW MARK		ROOM NAME SYMBOL		INTERIOR ELEVATION
	KEY NOTETAG		VIEW OF SECTION		REVISION CLOUD & REVISION NUMBER
	WALL TAG		SECTION-GLOSS SYMBOL		



### ABBREVIATIONS (REFER TO CONSULTANT DRAWINGS FOR ADDITIONAL ABBREVIATIONS)

AB ANCHOR BOLT	DF DRIVING FOUNTAIN	GA GAGE	MATL MATERIAL	PAF POWDER ACTUATED	S SOUTH	VET VENTILATION TYPE
ACST ACOUSTIC	DIA DIAMETER	MAX GALV GALVANIZED	MAX MAXIMUM	FASTENER	SC SOLID CORE	VERT VERTICAL
ADJ ADJUSTABLE ADJUST	DM DIMENSION	GB GRAB BAR	MB MACHINE BOLT	PBD PARTICLE BOARD	SCR SCREW	VTR VENT THROUGH ROOF
AFF ABOVE FINISHED FLOOR	DMV DIMED, DIVIDED, DIVISION	GL GLASS	MECH MECHANICAL	PL PLASTER LINE, PLATE	SD SLOPE DISPENSER	
ALUM ALUMINUM	DR DOOR	CLL-AM BEAM CUL-AM BEAM	MFR MANUFACTURER	PLM PLASTIC LAMINATE	SDR SMOKE DETECTOR	
AWDD ANCHORED	DS DOWNSPOUT	GYP-SUB BOARD GYPSUM BOARD	MH MANHOLE	PLB PLUMBING	SDR Drain SLOPE DETECTOR	
APPROX APPROXIMATELY	DTL DETAIL	QTL DETAIL	MI MIRROR	PLYWD PLYWOOD	SF SQUARE FOOT	
ASPH ASPHALT	DWG DRAWING	HS HOSE (E8B)	MM MIRROR	PNL PANEL	SF BREATHING SHEET	
	HCP HANDCAP	HOLLOW CORE HDR HEADER	MEC MECHANICAL	PRG PARTING	SM SMALL	
BD BOARD	E EAST	HDR HANDWARE	MD MAJOR DRAINING	PTD PARTICTION DISPENSER	SPK SPOKE	
BLDG BUILDING	EA EACH	HWC HOLLOW CORE	MT MECHTRY	PTD PARTITION	SPR SPREADER	
BLGC BLOCKING	EF EXHAUST FAN	HC HOLLOW CORE	MT METAL	PTD PARTITION	SQ SQUARE	
BM BENCH MARK BEAM	EJ EXPANSION JOINT	HRS HORIZONTAL	N NORTH	PT POINT	SKB SERVICE BANK	
BOT BOTTOM	EL ELEVATION	HSS HOLLOW STEEL	NIC NORTH IN CONTACT	PVMT PAVEMENT	SST STAINLESS STEEL	
BLR BURL UP ROOFING	EQ EQUAL	HST HIGH STRENGTH HEAD	NL NORTH LIGHT	QUAL QUALITY	STD STANDARD	
	ELEV ELEVATION	HT HEATING VENTILATING	NO NUMBER	RD RADIUS, R/SBR	STRG STRUCTURE, STRUCTURAL	
CAB CABINET	EQ EQUAL	HW HEAT W/ATER	NTS NOT TO SCALE	RC REBAR, R/SBR	SUSP SUSPENDED	
CB CATCH BASIN, CORNER BEAD	EQ EQUAL	INSUL INSULATE, INSULATED	DA OVERALL OUTSIDE AIR	RD RADIUS, R/SBR	TEMP TEMPERED, TREAD	
CC CORNER GUARD	EQ EQUAL	INSUL INSULATE, INSULATED	DB OVERALL OUTSIDE AIR	RC REBAR, R/SBR	TEL TELEPHONE	
CHD CHAMBOARD	EQ EQUAL	INSUL INSULATE, INSULATED	DB OVERALL OUTSIDE AIR	RC REBAR, R/SBR	TAG TAG	
CJ CAST IRON	EQ EQUAL	INSUL INSULATE, INSULATED	DB OVERALL OUTSIDE AIR	RC REBAR, R/SBR	TAG TAG	
CK CONTROL JOINT	EQ EQUAL	INSUL INSULATE, INSULATED	DB OVERALL OUTSIDE AIR	RC REBAR, R/SBR	TAG TAG	
CLD CEILING	EQ EQUAL	INSUL INSULATE, INSULATED	DB OVERALL OUTSIDE AIR	RC REBAR, R/SBR	TAG TAG	
CLR CLEAR CLEARANCE	EQ EQUAL	INSUL INSULATE, INSULATED	DB OVERALL OUTSIDE AIR	RC REBAR, R/SBR	TAG TAG	
CMU CONCRETE MASONRY UNIT	EQ EQUAL	INSUL INSULATE, INSULATED	DB OVERALL OUTSIDE AIR	RC REBAR, R/SBR	TAG TAG	
COL COLUMN	EQ EQUAL	INSUL INSULATE, INSULATED	DB OVERALL OUTSIDE AIR	RC REBAR, R/SBR	TAG TAG	
CONC CONCRETE	EQ EQUAL	INSUL INSULATE, INSULATED	DB OVERALL OUTSIDE AIR	RC REBAR, R/SBR	TAG TAG	
CONTR CONTRACTION	EQ EQUAL	INSUL INSULATE, INSULATED	DB OVERALL OUTSIDE AIR	RC REBAR, R/SBR	TAG TAG	
CONT CONTINUOUS CONTINUE	EQ EQUAL	INSUL INSULATE, INSULATED	DB OVERALL OUTSIDE AIR	RC REBAR, R/SBR	TAG TAG	
CONTR CONTRACTION	EQ EQUAL	INSUL INSULATE, INSULATED	DB OVERALL OUTSIDE AIR	RC REBAR, R/SBR	TAG TAG	
CNS COURSE, COURSES	EQ EQUAL	INSUL INSULATE, INSULATED	DB OVERALL OUTSIDE AIR	RC REBAR, R/SBR	TAG TAG	
CSK COUNTERSINK, COUNTERSUNK	EQ EQUAL	INSUL INSULATE, INSULATED	DB OVERALL OUTSIDE AIR	RC REBAR, R/SBR	TAG TAG	
CW COLD WATER	EQ EQUAL	INSUL INSULATE, INSULATED	DB OVERALL OUTSIDE AIR	RC REBAR, R/SBR	TAG TAG	
	EQ EQUAL	INSUL INSULATE, INSULATED	DB OVERALL OUTSIDE AIR	RC REBAR, R/SBR	TAG TAG	

## MATERIAL REFERENCE

	EARTH		LOOSE BATT INSUL
	GRANULAR FILL		RIGID INSULATION
	CONCRETE		CLASSE
	PLASTER GROUT		METAL
	ASPHALT		PLYWOOD
	FINISH WOOD		CONCRETE MASONRY UNITS
	DIMENSION		GYPSUM WALLBOARD
	ACOUSTICAL TILE		CERAMIC TILE

## PROJECT DIRECTORY

OWNER:  
SOUTHWESTERN POLK COUNTY RURAL  
FIRE PROTECTION DISTRICT  
230 SW HALL STREET  
SEASIDE, OREGON 97138  
PHONE: (503) 843-2487

ARCHITECT:  
CARLSON VEIT JUNGE ARCHITECTS  
1325 LIBERTY STREET SE  
SALEM, OREGON 97302  
PHONE: (503) 394-4207

STRUCTURAL & CIVIL ENGINEER:  
LUCAS ENGINEERS, INC.  
139 S LIBERTY STREET SE  
SALEM, OREGON 97302  
PHONE: (503) 394-4207

MECHANICAL & PLUMBING ENGINEER:  
RAJ ENGINEERING DESIGN  
1901 NE 10TH AVE  
PELOHAM, OREGON 97270  
PHONE: (503) 271-0029

ELECTRICAL ENGINEER:  
LANDIS CONSULTING  
8400 FARWAY AVENUE SE, SUITE 220  
SALEM, OREGON 97208  
PHONE: (503) 394-1978

## INDEX OF DRAWINGS

<b>GENERAL</b>	<b>FIRE PROTECTION</b>	<b>MECHANICAL, PLUMBING,</b>
G-001 TITLE SHEET & CODE SUMMARY	G-002 COVER SHEET	MP-001 SYMBOLS, LEGEND, ABBREVIATIONS
C-001 CIVIL COVER PAGE AND LEGEND	M-100 HVAC 1ST FLOOR PLAN	M-101 HVAC 2ND FLOOR PLAN
C-101 CIVIL GENERAL NOTES	M-102 REFRIGERANT PIPING 1ST FLOOR PLAN	M-103 REFRIGERANT PIPING 2ND FLOOR PLAN
C-102 OVERALL CIVIL SITE PLAN	M-300 MECHANICAL SECTIONS	M-400 MECHANICAL ROOM PLAN
C-103 CIVIL DIMENSION PLAN	M-401 SYSTEM REFERENCE FLOW DIAGRAM	M-402 MECHANICAL FLOW DIAGRAM
C-104 MECHANICAL DIMENSION PLAN	M-403 MECHANICAL DETAILS S	M-404 MECHANICAL DETAILS S
C-105 MECHANICAL UTILITY PLAN	M-405 MECHANICAL DETAILS S	M-406 MECHANICAL SCHEDULES
C-106 MECHANICAL UTILITY PLAN	M-407 MECHANICAL SCHEDULES	M-408 MECHANICAL SCHEDULES
C-107 MECHANICAL UTILITY PLAN	M-409 MECHANICAL SCHEDULES	M-410 MECHANICAL SCHEDULES
C-108 MECHANICAL UTILITY PLAN	M-411 MECHANICAL SCHEDULES	M-412 MECHANICAL SCHEDULES
C-109 MECHANICAL UTILITY PLAN	M-413 MECHANICAL SCHEDULES	M-414 MECHANICAL SCHEDULES
C-110 MECHANICAL UTILITY PLAN	M-415 MECHANICAL SCHEDULES	M-416 MECHANICAL SCHEDULES
C-111 MECHANICAL UTILITY PLAN	M-417 MECHANICAL SCHEDULES	M-418 MECHANICAL SCHEDULES
C-112 MECHANICAL UTILITY PLAN	M-419 MECHANICAL SCHEDULES	M-420 MECHANICAL SCHEDULES
C-113 MECHANICAL UTILITY PLAN	M-421 MECHANICAL SCHEDULES	M-422 MECHANICAL SCHEDULES
C-114 MECHANICAL UTILITY PLAN	M-423 MECHANICAL SCHEDULES	M-424 MECHANICAL SCHEDULES
C-115 MECHANICAL UTILITY PLAN	M-425 MECHANICAL SCHEDULES	M-426 MECHANICAL SCHEDULES
C-116 MECHANICAL UTILITY PLAN	M-427 MECHANICAL SCHEDULES	M-428 MECHANICAL SCHEDULES
C-117 MECHANICAL UTILITY PLAN	M-429 MECHANICAL SCHEDULES	M-430 MECHANICAL SCHEDULES
C-118 MECHANICAL UTILITY PLAN	M-431 MECHANICAL SCHEDULES	M-432 MECHANICAL SCHEDULES
C-119 MECHANICAL UTILITY PLAN	M-433 MECHANICAL SCHEDULES	M-434 MECHANICAL SCHEDULES
C-120 MECHANICAL UTILITY PLAN	M-435 MECHANICAL SCHEDULES	M-436 MECHANICAL SCHEDULES
C-121 MECHANICAL UTILITY PLAN	M-437 MECHANICAL SCHEDULES	M-438 MECHANICAL SCHEDULES
C-122 MECHANICAL UTILITY PLAN	M-439 MECHANICAL SCHEDULES	M-440 MECHANICAL SCHEDULES
C-123 MECHANICAL UTILITY PLAN	M-441 MECHANICAL SCHEDULES	M-442 MECHANICAL SCHEDULES
C-124 MECHANICAL UTILITY PLAN	M-443 MECHANICAL SCHEDULES	M-444 MECHANICAL SCHEDULES
C-125 MECHANICAL UTILITY PLAN	M-445 MECHANICAL SCHEDULES	M-446 MECHANICAL SCHEDULES
C-126 MECHANICAL UTILITY PLAN	M-447 MECHANICAL SCHEDULES	M-448 MECHANICAL SCHEDULES
C-127 MECHANICAL UTILITY PLAN	M-449 MECHANICAL SCHEDULES	M-450 MECHANICAL SCHEDULES
C-128 MECHANICAL UTILITY PLAN	M-451 MECHANICAL SCHEDULES	M-452 MECHANICAL SCHEDULES
C-129 MECHANICAL UTILITY PLAN	M-453 MECHANICAL SCHEDULES	M-454 MECHANICAL SCHEDULES
C-130 MECHANICAL UTILITY PLAN	M-455 MECHANICAL SCHEDULES	M-456 MECHANICAL SCHEDULES
C-131 MECHANICAL UTILITY PLAN	M-457 MECHANICAL SCHEDULES	M-458 MECHANICAL SCHEDULES
C-132 MECHANICAL UTILITY PLAN	M-459 MECHANICAL SCHEDULES	M-460 MECHANICAL SCHEDULES
C-133 MECHANICAL UTILITY PLAN	M-461 MECHANICAL SCHEDULES	M-462 MECHANICAL SCHEDULES
C-134 MECHANICAL UTILITY PLAN	M-463 MECHANICAL SCHEDULES	M-464 MECHANICAL SCHEDULES
C-135 MECHANICAL UTILITY PLAN	M-465 MECHANICAL SCHEDULES	M-466 MECHANICAL SCHEDULES
C-136 MECHANICAL UTILITY PLAN	M-467 MECHANICAL SCHEDULES	M-468 MECHANICAL SCHEDULES
C-137 MECHANICAL UTILITY PLAN	M-469 MECHANICAL SCHEDULES	M-470 MECHANICAL SCHEDULES
C-138 MECHANICAL UTILITY PLAN	M-471 MECHANICAL SCHEDULES	M-472 MECHANICAL SCHEDULES
C-139 MECHANICAL UTILITY PLAN	M-473 MECHANICAL SCHEDULES	M-474 MECHANICAL SCHEDULES
C-140 MECHANICAL UTILITY PLAN	M-475 MECHANICAL SCHEDULES	M-476 MECHANICAL SCHEDULES
C-141 MECHANICAL UTILITY PLAN	M-477 MECHANICAL SCHEDULES	M-478 MECHANICAL SCHEDULES
C-142 MECHANICAL UTILITY PLAN	M-479 MECHANICAL SCHEDULES	M-480 MECHANICAL SCHEDULES
C-143 MECHANICAL UTILITY PLAN	M-481 MECHANICAL SCHEDULES	M-482 MECHANICAL SCHEDULES
C-144 MECHANICAL UTILITY PLAN	M-483 MECHANICAL SCHEDULES	M-484 MECHANICAL SCHEDULES
C-145 MECHANICAL UTILITY PLAN	M-485 MECHANICAL SCHEDULES	M-486 MECHANICAL SCHEDULES
C-146 MECHANICAL UTILITY PLAN	M-487 MECHANICAL SCHEDULES	M-488 MECHANICAL SCHEDULES
C-147 MECHANICAL UTILITY PLAN	M-489 MECHANICAL SCHEDULES	M-490 MECHANICAL SCHEDULES
C-148 MECHANICAL UTILITY PLAN	M-491 MECHANICAL SCHEDULES	M-492 MECHANICAL SCHEDULES
C-149 MECHANICAL UTILITY PLAN	M-493 MECHANICAL SCHEDULES	M-494 MECHANICAL SCHEDULES
C-150 MECHANICAL UTILITY PLAN	M-495 MECHANICAL SCHEDULES	M-496 MECHANICAL SCHEDULES
C-151 MECHANICAL UTILITY PLAN	M-497 MECHANICAL SCHEDULES	M-498 MECHANICAL SCHEDULES
C-152 MECHANICAL UTILITY PLAN	M-499 MECHANICAL SCHEDULES	M-500 MECHANICAL SCHEDULES
C-153 MECHANICAL UTILITY PLAN	M-501 MECHANICAL SCHEDULES	M-502 MECHANICAL SCHEDULES
C-154 MECHANICAL UTILITY PLAN	M-503 MECHANICAL SCHEDULES	M-504 MECHANICAL SCHEDULES
C-155 MECHANICAL UTILITY PLAN	M-505 MECHANICAL SCHEDULES	M-506 MECHANICAL SCHEDULES
C-156 MECHANICAL UTILITY PLAN	M-507 MECHANICAL SCHEDULES	M-508 MECHANICAL SCHEDULES
C-157 MECHANICAL UTILITY PLAN	M-509 MECHANICAL SCHEDULES	M-510 MECHANICAL SCHEDULES
C-158 MECHANICAL UTILITY PLAN	M-511 MECHANICAL SCHEDULES	M-512 MECHANICAL SCHEDULES
C-159 MECHANICAL UTILITY PLAN	M-513 MECHANICAL SCHEDULES	M-514 MECHANICAL SCHEDULES
C-160 MECHANICAL UTILITY PLAN	M-515 MECHANICAL SCHEDULES	M-516 MECHANICAL SCHEDULES
C-161 MECHANICAL UTILITY PLAN	M-517 MECHANICAL SCHEDULES	M-518 MECHANICAL SCHEDULES
C-162 MECHANICAL UTILITY PLAN	M-519 MECHANICAL SCHEDULES	M-520 MECHANICAL SCHEDULES
C-163 MECHANICAL UTILITY PLAN	M-521 MECHANICAL SCHEDULES	M-522 MECHANICAL SCHEDULES
C-164 MECHANICAL UTILITY PLAN	M-523 MECHANICAL SCHEDULES	M-524 MECHANICAL SCHEDULES
C-165 MECHANICAL UTILITY PLAN	M-525 MECHANICAL SCHEDULES	M-526 MECHANICAL SCHEDULES
C-166 MECHANICAL UTILITY PLAN	M-527 MECHANICAL SCHEDULES	M-528 MECHANICAL SCHEDULES
C-167 MECHANICAL UTILITY PLAN	M-529 MECHANICAL SCHEDULES	M-530 MECHANICAL SCHEDULES
C-168 MECHANICAL UTILITY PLAN	M-531 MECHANICAL SCHEDULES	M-532 MECHANICAL SCHEDULES
C-169 MECHANICAL UTILITY PLAN	M-533 MECHANICAL SCHEDULES	M-534 MECHANICAL SCHEDULES
C-170 MECHANICAL UTILITY PLAN	M-535 MECHANICAL SCHEDULES	M-536 MECHANICAL SCHEDULES
C-171 MECHANICAL UTILITY PLAN	M-537 MECHANICAL SCHEDULES	M-538 MECHANICAL SCHEDULES
C-172 MECHANICAL UTILITY PLAN	M-539 MECHANICAL SCHEDULES	M-540 MECHANICAL SCHEDULES
C-173 MECHANICAL UTILITY PLAN	M-541 MECHANICAL SCHEDULES	M-542 MECHANICAL SCHEDULES
C-174 MECHANICAL UTILITY PLAN	M-543 MECHANICAL SCHEDULES	M-544 MECHANICAL SCHEDULES
C-175 MECHANICAL UTILITY PLAN	M-545 MECHANICAL SCHEDULES	M-546 MECHANICAL SCHEDULES
C-176 MECHANICAL UTILITY PLAN	M-547 MECHANICAL SCHEDULES	M-548 MECHANICAL SCHEDULES
C-177 MECHANICAL UTILITY PLAN	M-549 MECHANICAL SCHEDULES	M-550 MECHANICAL SCHEDULES
C-178 MECHANICAL UTILITY PLAN	M-551 MECHANICAL SCHEDULES	M-552 MECHANICAL SCHEDULES
C-179 MECHANICAL UTILITY PLAN	M-553 MECHANICAL SCHEDULES	M-554 MECHANICAL SCHEDULES
C-180 MECHANICAL UTILITY PLAN	M-555 MECHANICAL SCHEDULES	M-556 MECHANICAL SCHEDULES
C-181 MECHANICAL UTILITY PLAN	M-557 MECHANICAL SCHEDULES	M-558 MECHANICAL SCHEDULES
C-182 MECHANICAL UTILITY PLAN	M-559 MECHANICAL SCHEDULES	M-560 MECHANICAL SCHEDULES
C-183 MECHANICAL UTILITY PLAN	M-561 MECHANICAL SCHEDULES	M-562 MECHANICAL SCHEDULES
C-184 MECHANICAL UTILITY PLAN	M-563 MECHANICAL SCHEDULES	M-564 MECHANICAL SCHEDULES
C-185 MECHANICAL UTILITY PLAN	M-565 MECHANICAL SCHEDULES	M-566 MECHANICAL SCHEDULES
C-186 MECHANICAL UTILITY PLAN	M-567 MECHANICAL SCHEDULES	M-568 MECHANICAL SCHEDULES
C-187 MECHANICAL UTILITY PLAN	M-569 MECHANICAL SCHEDULES	M-570 MECHANICAL SCHEDULES
C-188 MECHANICAL UTILITY PLAN	M-571 MECHANICAL SCHEDULES	M-572 MECHANICAL SCHEDULES
C-189 MECHANICAL UTILITY PLAN	M-573 MECHANICAL SCHEDULES	M-574 MECHANICAL SCHEDULES
C-190 MECHANICAL UTILITY PLAN	M-575 MECHANICAL SCHEDULES	M-576 MECHANICAL SCHEDULES
C-191 MECHANICAL UTILITY PLAN	M-577 MECHANICAL SCHEDULES	M-578 MECHANICAL SCHEDULES
C-192 MECHANICAL UTILITY PLAN	M-579 MECHANICAL SCHEDULES	M-580 MECHANICAL SCHEDULES
C-193 MECHANICAL UTILITY PLAN	M-581 MECHANICAL SCHEDULES	M-582 MECHANICAL SCHEDULES
C-194 MECHANICAL UTILITY PLAN	M-583 MECHANICAL SCHEDULES	M-584 MECHANICAL SCHEDULES
C-195 MECHANICAL UTILITY PLAN	M-585 MECHANICAL SCHEDULES	M-586 MECHANICAL SCHEDULES
C-196 MECHANICAL UTILITY PLAN	M-587 MECHANICAL SCHEDULES	M-588 MECHANICAL SCHEDULES
C-197 MECHANICAL UTILITY PLAN	M-589 MECHANICAL SCHEDULES	M-590 MECHANICAL SCHEDULES
C-198 MECHANICAL UTILITY PLAN	M-591 MECHANICAL SCHEDULES	M-592 MECHANICAL SCHEDULES
C-199 MECHANICAL UTILITY PLAN	M-593 MECHANICAL SCHEDULES	M-594 MECHANICAL SCHEDULES
C-200 MECHANICAL UTILITY PLAN	M-595 MECHANICAL SCHEDULES	M-596 MECHANICAL SCHEDULES
C-201 MECHANICAL UTILITY PLAN	M-597 MECHANICAL SCHEDULES	M-598 MECHANICAL SCHEDULES
C-202 MECHANICAL UTILITY PLAN	M-599 MECHANICAL SCHEDULES	M-600 MECHANICAL SCHEDULES
C-203 MECHANICAL UTILITY PLAN	M-601 MECHANICAL SCHEDULES	M-602 MECHANICAL SCHEDULES
C-204 MECHANICAL UTILITY PLAN	M-603 MECHANICAL SCHEDULES	M-604 MECHANICAL SCHEDULES
C-205 MECHANICAL UTILITY PLAN	M-605 MECHANICAL SCHEDULES	M-606 MECHANICAL SCHEDULES
C-206 MECHANICAL UTILITY PLAN	M-607 MECHANICAL SCHEDULES	M-608 MECHANICAL SCHEDULES
C-207 MECHANICAL UTILITY PLAN	M-609 MECHANICAL SCHEDULES	M-610 MECHANICAL SCHEDULES
C-208 MECHANICAL UTILITY PLAN	M-611 MECHANICAL SCHEDULES	M-612 MECHANICAL SCHEDULES
C-209 MECHANICAL UTILITY PLAN	M-613 MECHANICAL SCHEDULES	M-614 MECHANICAL SCHEDULES
C-210 MECHANICAL UTILITY PLAN	M-615 MECHANICAL SCHEDULES	M-616 MECHANICAL SCHEDULES
C-211 MECHANICAL UTILITY PLAN	M-617 MECHANICAL SCHEDULES	M-618 MECHANICAL SCHEDULES
C-212 MECHANICAL UTILITY PLAN	M-619 MECHANICAL SCHEDULES	M-620 MECHANICAL SCHEDULES
C-213 MECHANICAL UTILITY PLAN	M-621 MECHANICAL SCHEDULES	M-622 MECHANICAL SCHEDULES
C-214 MECHANICAL UTILITY PLAN	M-623 MECHANICAL SCHEDULES	M-624 MECHANICAL SCHEDULES
C-215 MECHANICAL UTILITY PLAN	M-625 MECHANICAL SCHEDULES	M-626 MECHANICAL SCHEDULES
C-216 MECHANICAL UTILITY PLAN	M-627 MECHANICAL SCHEDULES	M-628 MECHANICAL SCHEDULES
C-217 MECHANICAL UTILITY PLAN	M-629 MECHANICAL SCHEDULES	M-630 MECHANICAL SCHEDULES
C-218 MECHANICAL UTILITY PLAN	M-631 MECHANICAL SCHEDULES	M-632 MECHANICAL SCHEDULES
C-219 MECHANICAL UTILITY PLAN	M-633 MECHANICAL SCHEDULES	M-634 MECHANICAL SCHEDULES
C-220 MECHANICAL UTILITY PLAN	M-635 MECHANICAL SCHEDULES	M-636 MECHANICAL SCHEDULES
C-221 MECHANICAL UTILITY PLAN	M-637 MECHANICAL SCHEDULES	M-638 MECHANICAL SCHEDULES
C-222 MECHANICAL UTILITY PLAN	M-639 MECHANICAL SCHEDULES	M-640 MECHANICAL SCHEDULES
C-223 MECHANICAL UTILITY PLAN	M-641 MECHANICAL SCHEDULES	M-642 MECHANICAL SCHEDULES
C-224 MECHANICAL UTILITY PLAN	M-643 MECHANICAL SCHEDULES	M-644 MECHANICAL SCHEDULES
C-225 MECHANICAL UTILITY PLAN	M-645 MECHANICAL SCHEDULES	M-646 MECHANICAL SCHEDULES
C-226 MECHANICAL UTILITY PLAN	M-647 MECHANICAL SCHEDULES	M-648 MECHANICAL SCHEDULES
C-227 MECHANICAL UTILITY PLAN	M-649 MECHANICAL SCHEDULES	M-650 MECHANICAL SCHEDULES
C-228 MECHANICAL UTILITY PLAN	M-651 MECHANICAL SCHEDULES	M-652 MECHANICAL SCHEDULES
C-229 MECHANICAL UTILITY PLAN	M-653 MECHANICAL SCHEDULES	M-654 MECHANICAL SCHEDULES
C-230 MECHANICAL UTILITY PLAN	M-655 MECHANICAL SCHEDULES	M-656 MECHANICAL SCHEDULES
C-231 MECHANICAL UTILITY PLAN	M-657 MECHANICAL SCHEDULES	M-658 MECHANICAL SCHEDULES
C-232 MECHANICAL UTILITY PLAN	M-659 MECHANICAL SCHEDULES	M-660 MECHANICAL SCHEDULES
C-233 MECHANICAL UTILITY PLAN	M-661 MECHANICAL SCHEDULES	M-662 MECHANICAL SCHEDULES
C-234 MECHANICAL UTILITY PLAN	M	

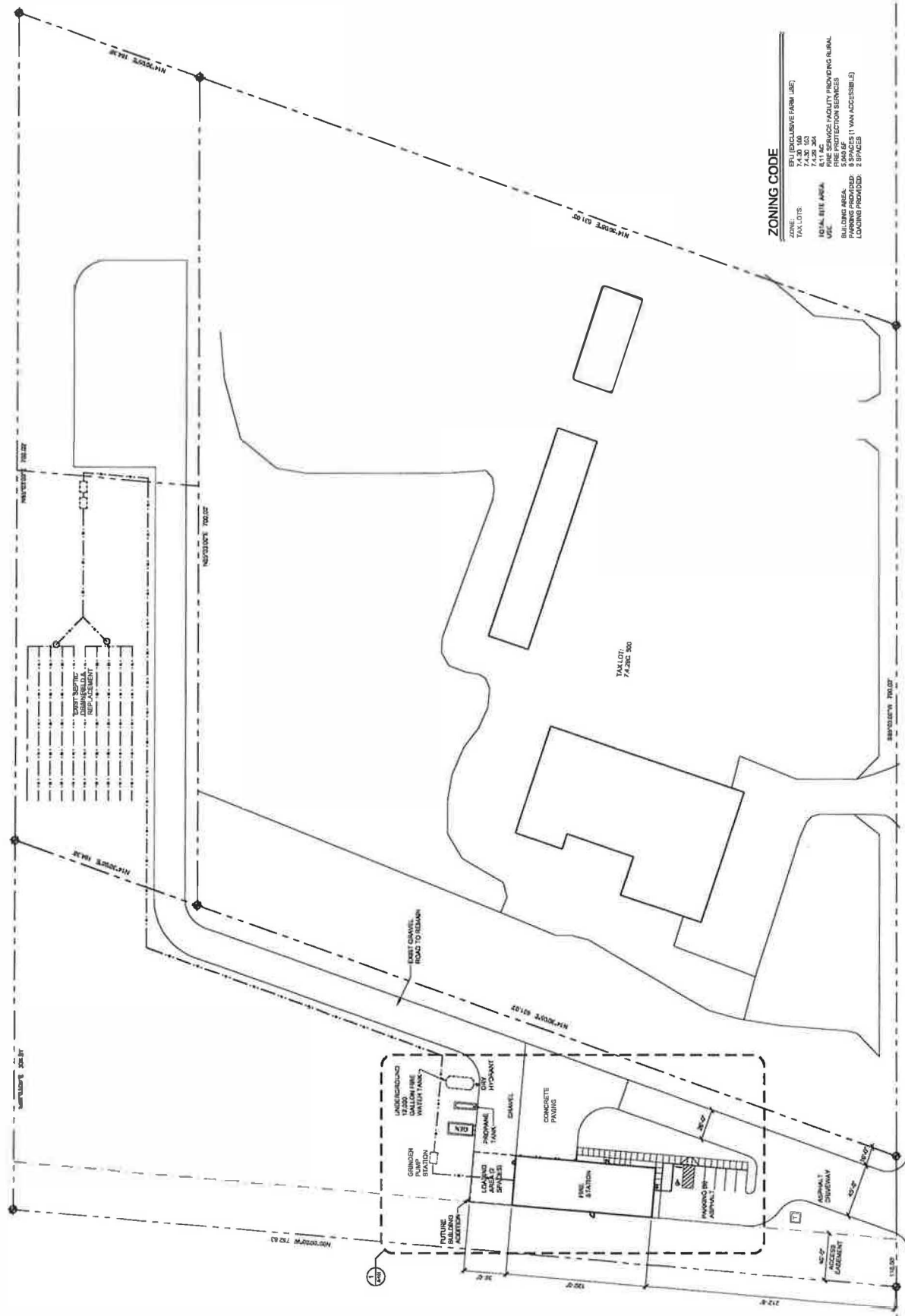

**ZONING CODE**

ZONE	EFU (EXCLUSIVE FARM USE)
PARCELS	74.30.03 74.30.04 74.30.05
TOTAL SITE AREA	8.11 AC.
USE	FIRE SERVICE FACILITY PROVIDING RURAL FIRE PROTECTION SERVICES
BUILDING AREA	5,000 SF
LOADING SPACES	1 (VAN ACCESSIBLE)
LOADING PROVIDED	2 SPACES

DOOR SCHEDULE										
DOOR MARK	SIZE W X H X THK	TYPE	CONET (D)	FINISH (M)	CLASS (U)	FRAMA		RATING (7)	HOW (8)	REMARKS (9)
						CONET (D)	FINISH (M)			
101A	8'-0" x 7'-0" x 1-3/4"	A	INS	ME	-	HS	ME	2, 7, 12 (A-201)		
101B	15'-0" x 7'-0" x 1-3/4"	B	CON	FF	TAN	-	ME	1, 8, 14 (A-201)		
101C	13'-0" x 7'-0" x 1-3/4"	B	CON	FF	TAN	-	ME	1, 8, 14 (A-201)		
101D	15'-0" x 7'-0" x 1-3/4"	B	CON	FF	TAN	-	ME	1, 8, 14 (A-201)		
101E	8'-0" x 7'-0" x 1-3/4"	C	INS	ME	-	HS	ME	11, 10 (A-201)		
101F	8'-0" x 7'-0" x 1-3/4"	C	INS	ME	-	HS	ME	11, 10 (A-201)		
101G	8'-0" x 7'-0" x 1-3/4"	C	INS	ME	-	HS	ME	11, 10 (A-201)		
101H	8'-0" x 7'-0" x 1-3/4"	C	INS	ME	-	HS	ME	11, 10 (A-201)		
101I	8'-0" x 7'-0" x 1-3/4"	C	INS	ME	-	HS	ME	11, 10 (A-201)		
101J	8'-0" x 7'-0" x 1-3/4"	C	INS	ME	-	HS	ME	11, 10 (A-201)		
101K	8'-0" x 7'-0" x 1-3/4"	C	INS	ME	-	HS	ME	11, 10 (A-201)		
101L	8'-0" x 7'-0" x 1-3/4"	C	INS	ME	-	HS	ME	11, 10 (A-201)		
101M	8'-0" x 7'-0" x 1-3/4"	C	INS	ME	-	HS	ME	11, 10 (A-201)		
101N	8'-0" x 7'-0" x 1-3/4"	C	INS	ME	-	HS	ME	11, 10 (A-201)		
101O	8'-0" x 7'-0" x 1-3/4"	C	INS	ME	-	HS	ME	11, 10 (A-201)		
101P	8'-0" x 7'-0" x 1-3/4"	C	INS	ME	-	HS	ME	11, 10 (A-201)		
101Q	8'-0" x 7'-0" x 1-3/4"	C	INS	ME	-	HS	ME	11, 10 (A-201)		
101R	8'-0" x 7'-0" x 1-3/4"	C	INS	ME	-	HS	ME	11, 10 (A-201)		
101S	8'-0" x 7'-0" x 1-3/4"	C	INS	ME	-	HS	ME	11, 10 (A-201)		
101T	8'-0" x 7'-0" x 1-3/4"	C	INS	ME	-	HS	ME	11, 10 (A-201)		
101U	8'-0" x 7'-0" x 1-3/4"	C	INS	ME	-	HS	ME	11, 10 (A-201)		
101V	8'-0" x 7'-0" x 1-3/4"	C	INS	ME	-	HS	ME	11, 10 (A-201)		
101W	8'-0" x 7'-0" x 1-3/4"	C	INS	ME	-	HS	ME	11, 10 (A-201)		
101X	8'-0" x 7'-0" x 1-3/4"	C	INS	ME	-	HS	ME	11, 10 (A-201)		
101Y	8'-0" x 7'-0" x 1-3/4"	C	INS	ME	-	HS	ME	11, 10 (A-201)		
101Z	8'-0" x 7'-0" x 1-3/4"	C	INS	ME	-	HS	ME	11, 10 (A-201)		

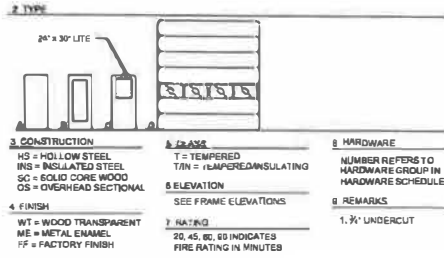

**GENERAL NOTES**

- EXTERIOR WALLS: METAL SIDING, R-3 THERMAL SPACER BLOCK, 8\"/>
- INTERIOR WALLS: 3\"/>
- FURNITURE IS TO BE ODFI LON
- CENTER LINE FEATURES IN ROOM OR SPACE, UNLESS NOTED

**CONSTRUCTION NOTES**

- 8\"/>
- 1 HOUR FIRE RATED, SEE DET. 1 (G) 02
- WALL FLOORING: 3\"/>
- WALL FLOORING: 1\"/>
- TURNOUT GEAR COMPARTMENTS: 0\"/>
- FINISH WALL
- FUTURE WALL-BIND FEATURE
- FUTURE WASH-HAND DRYER
- 4\"/>
- 1\"/>
- TOWEL HOOK
- SHOWER CURTAIN AND ROD
- 3\"/>

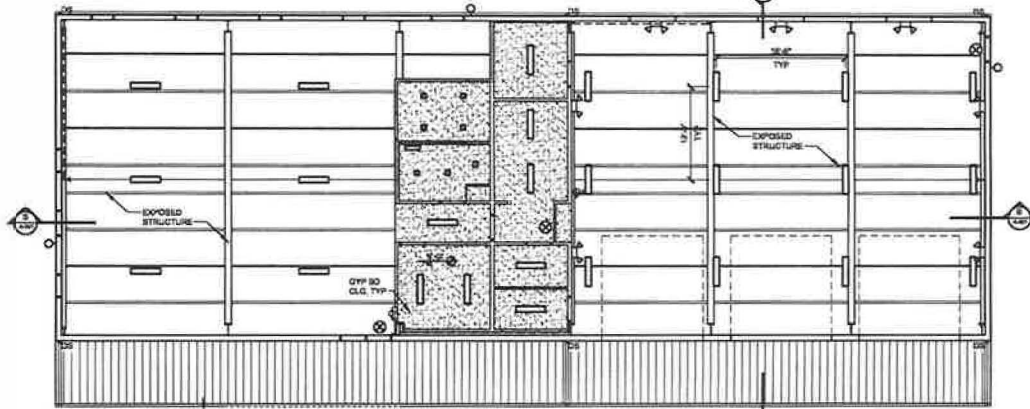
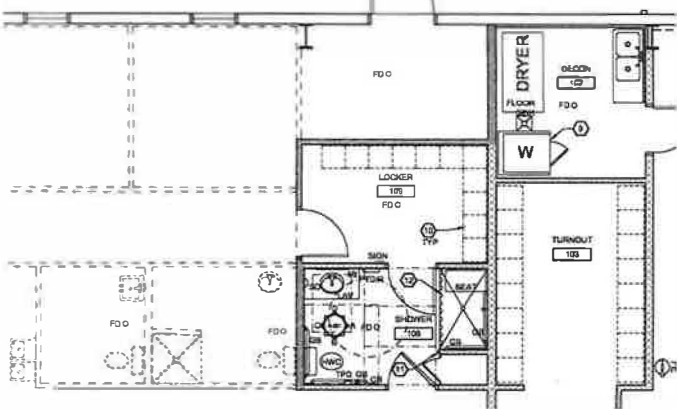

**REFLECTED CEILING PLAN**  
18\"/>

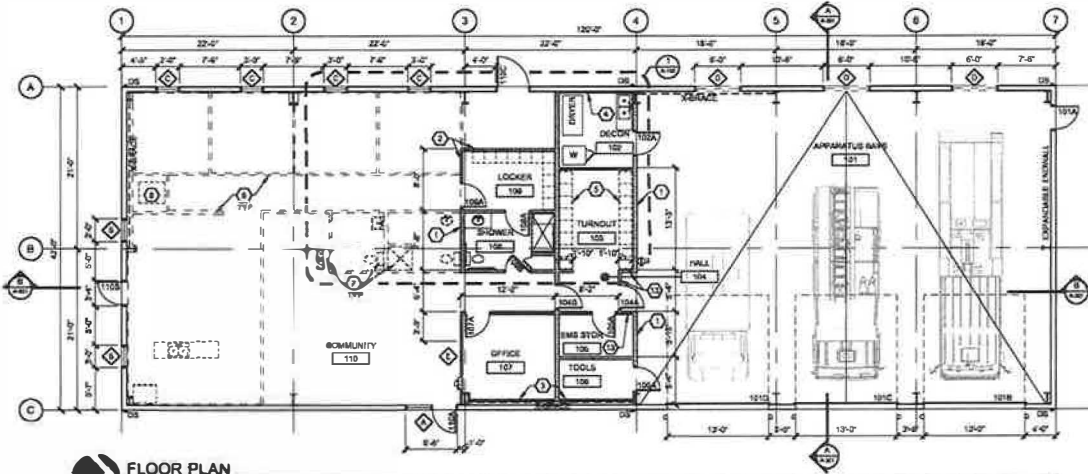

**FLOOR PLAN**  
18\"/>

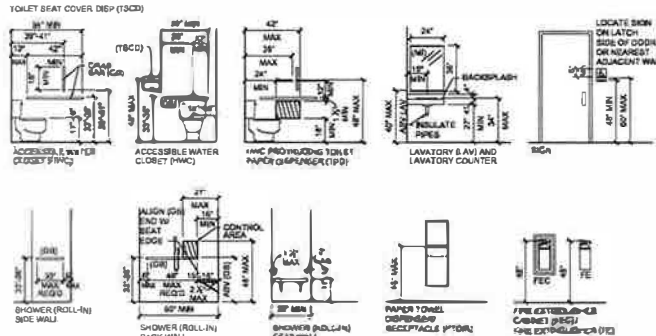

**FIXTURE MOUNTING HEIGHTS**  
TYPICAL, UNLESS OTHERWISE NOTED  
ALL DIMENSIONS ARE CLEAR FINISH

**CARLSON VEIT JUNGE ARCHITECTS PC**  
ARCHITECTS  
1000 UNIVERSITY BLVD., SUITE 1000, DENVER, CO 80202  
303.733.1234

**PRELIMINARY**  
NOT FOR CONSTRUCTION

PRELIMINARY DATE  
**02-06-2020**

**SW POLK FIRE DISTRICT  
RICKREALL STATION**  
1000 UNIVERSITY BLVD., SUITE 1000, DENVER, CO 80202

DATE: 02/06/20  
DRAWING NO.: A-102-X-02519  
DRAWN BY: NW  
CHECKED BY: [Signature]  
PROJECT: SW POLK FIRE DISTRICT RICKREALL STATION

**FLOOR PLANS & DOOR SCHEDULE**  
A-102

WINDOW SCHEDULE										
WIND MARK	OPERATION TYPE	FRONT FINISH (A)	FRONT FINISH (B)	FRAME FINISH (C)	GLASS TYPE (D)	GLASS COLOR (E)	GLASS THICKNESS (F)	REMARKS (G)		
A	F	HS	ME	1	TN	E				
B	F	V	FF	1	IN	E				
C	F	V	FF	1	IN	E				
D	F	V	FF	1	IN	E				

**A. OPERATION TYPE**  
 F = FIXED  
 T = TEMPORED  
 V = VENTILATING  
 S = SLIDER

**B. FRAME MATERIAL**  
 HS = HOLLOW STEEL  
 V = VINYL  
 AL = ALUMINUM

**C. FRAME FINISH**  
 ME = METAL ENAMEL  
 FF = FACTORY FINISH

**D. GLASS THICKNESS**  
 1/2" = 1/2" GLASS  
 3/4" = 3/4" GLASS  
 1" = 1" GLASS

**E. GLASS TYPE**  
 TN = TINTED  
 IN = INSULATING  
 TIW = TINTED/INSULATING

**F. GLASS COLOR**  
 C = CLEAR  
 E = LOW-E COATED

**G. WINDOW NOTES & GENERAL INFORMATION**

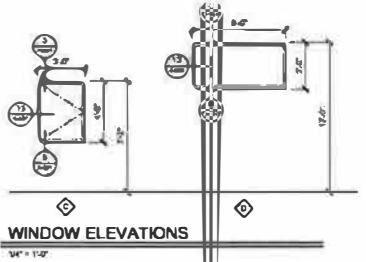
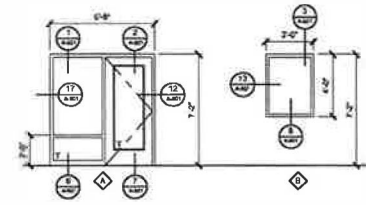

**WINDOW ELEVATIONS**  
 1/4" = 1'-0"

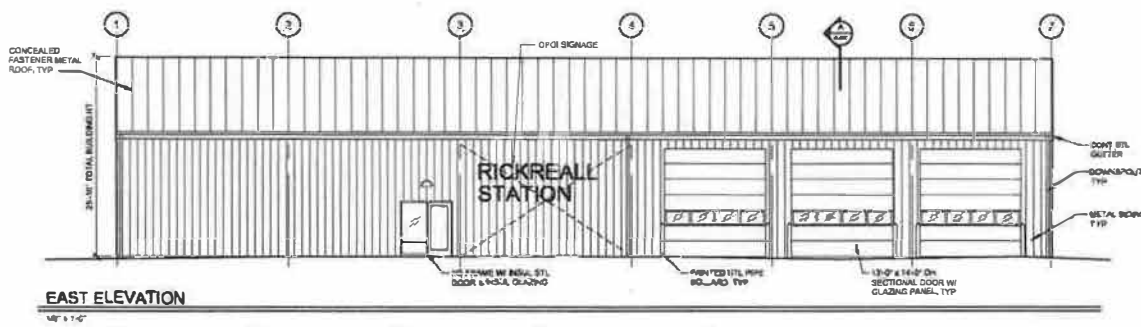

**EAST ELEVATION**  
 1/4" = 1'-0"

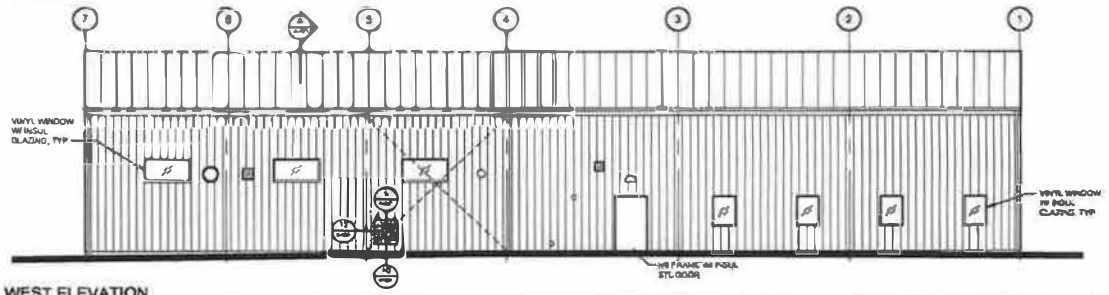

**WEST ELEVATION**  
 1/4" = 1'-0"

EXTERIOR FINISH SCHEDULE		
APPROVED MANUFACTURERS		COLOR
ROOF	TAYLOR METAL PRODUCTS AEP SPAN	SIERRA TAN
METAL SIDING	TAYLOR METAL PRODUCTS AEP SPAN	SIERRA TAN
EAVE/RURE TRIM, GUTTERS & DOWNSPOUTS	TAYLOR METAL PRODUCTS AEP SPAN	MUSKET
INSUL STL DOORS & HB FRAMES	FRUIT TO WATCH TRIM, GUTTERS & DOWNSPOUTS	
VINYL WINDOWS	WILCORP	ESPRESSO
PIPE BOLARDS		PANT BW 888

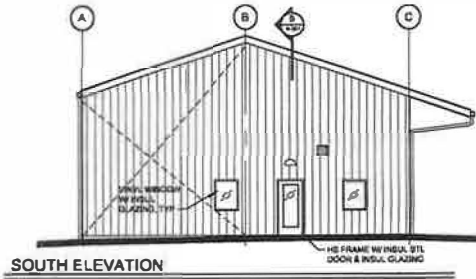

**SOUTH ELEVATION**  
 1/4" = 1'-0"

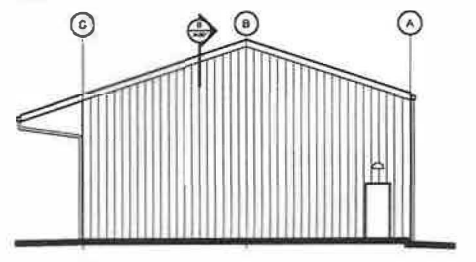

**NORTH ELEVATION**  
 1/4" = 1'-0"

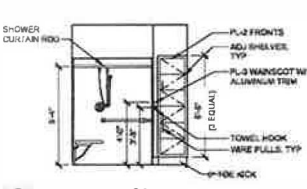

**A SHOWER 108**  
 1/4" = 1'-0"

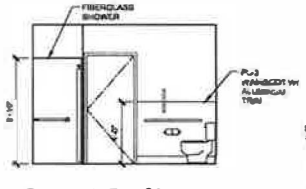

**B SHOWER 108**  
 1/4" = 1'-0"

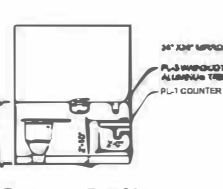

**C SHOWER 108**  
 1/4" = 1'-0"

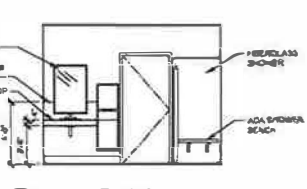

**D SHOWER 108**  
 1/4" = 1'-0"

CARLSON  
 VEIT  
 JUNGE  
 ARCHITECTS PC  
 4700 CHERRY LANE - SUITE 100  
 RICKREALL, OR 97151

PRELIMINARY  
 NOT FOR CONSTRUCTION  
 PRELIMINARY DATE  
 02-06-2020

PROJECT  
 SW POLK FIRE DISTRICT  
 RICKREALL STATION  
 8005 RICKREALL ROAD  
 RICKREALL, OR 97151

DATE  
 02/06/20  
 SHEET NO. A-201-S-02819  
 DRAWN BY: NFW  
 CHECKED BY:  
 COPYRIGHT © 2020  
 Carlson Veit Junge Architects PC  
 BUILDING &  
 WINDOW  
 ELEVATIONS  
 8/1/2020  
 A-201







PRELIMINARY  
NOT FOR CONSTRUCTION

DATE: 02-06-2020

Project: SW POLK FIRE DISTRICT  
BRIDGEPORT STATION  
Dallas, TX 75238  
664-4480-3444 BY HWY

Scale: DIST 1/8" = 1'-0"  
Sheet No. A-101-JBS10  
Created by: HW  
Checked by: HW  
Copyright © 2020  
Carlson Veit Junge Architects PC

SITE PLAN

A-101

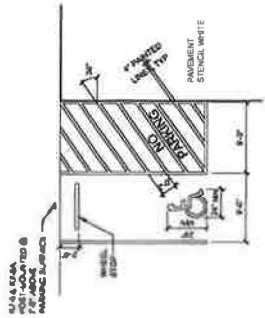

1 ACCESSIBLE PAINTED STRIPING  
1/2" x 4"

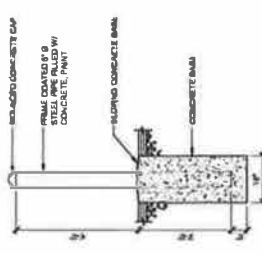

2 PIPE BOLLARD DETAIL  
12" x 4"

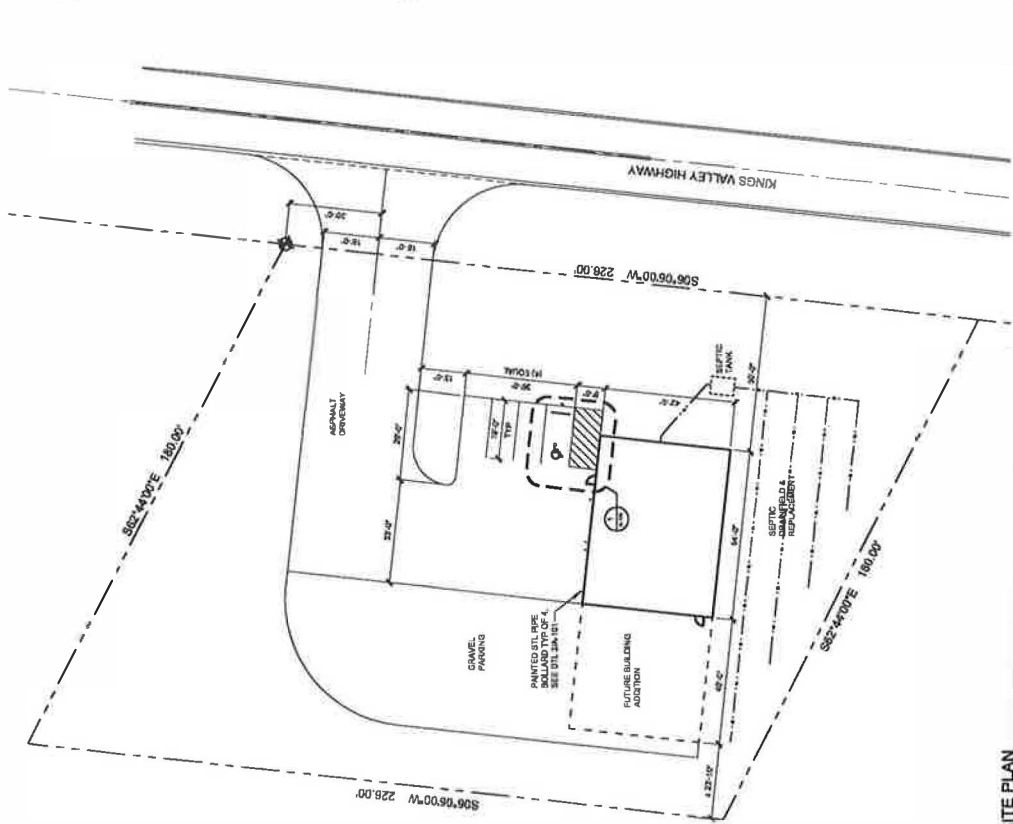

# CHIEF'S REPORT

- ❖ Upcoming Events
  - February 19: SDAO Risk Management Training in Salem
  - February 24-25: ESO Training in Austin
  - March 4-6: NW Leadership Seminar in Portland
  - March 31-April 2: Incident Management Team Training in Sunriver
  
- ❖ Firefighter/Paramedic position(s)
  - Applications closed with six total applicants
  - Civil Service Meeting approved the applicant list on January 30, 2020
  - Conditional job offers have been made to cover current or anticipated vacancies
  
- ❖ Through all three websites we are piloting a program using online payment for services like; address signs, FireMed, and cost recovery. This program:
  - Reduces staff time
  - Increases collection timeliness
  - Decreases billing costs
  - Has received positive public feedback
  
- ❖ Cooperative Services Study - data collection
  - Data collection components have been assigned to staff
  - Timelines for data collection have been established
  
- ❖ Dupee Valley residential fire on January 18, 2020:
  - An after-action review (AAR) has been created and shared
  - Staffing on the fire was as follows:

Agency/Group	Units	Volunteers	Career	Total Personnel
Admin Team	C191, BC140	0	2	2
Amity Fire	E5	5	0	5
Sheridan Fire	E191, WT197, WT198, BR198, WT191	8	2	10
SW Polk Fire	E137	2	0	2
McMinnville Fire	E1, WT1, WT10, M12	4	7	11
West Valley Fire	E181, M181	2	3	5
<b>Totals:</b>		<b>21</b>	<b>14</b>	<b>35</b>

- Other notes of interest:
  - M182 was on a medical call then later responded to the fire
  - M181 was on a medical with BR198 then later responded to the fire
  - Dallas Fire & EMS moved up to Station 197

- ❖ Grants that staff has submitted, are creating or administering:
  - SDAO Security Grant for new door lock systems for each agency \$5000/each
  - SDAO Intern Grant for SW Polk and West Valley submitted \$3000/each
  - VFA Wildland Grant for PPE \$10,000 award
  - Ford Family Foundation Grant for Salt Creek community room \$250,000
  - Oregon Seismic Grant for upgrade to Sheridan main station \$2,095,084
  - Working on FEMA AFG for firefighting equipment for each agency
  - Spirit Mountain Grant for WV auto-load power-cot system \$16,284 award
  - Spirit Mountain Grant for Sheridan medical equipment submitted \$49,749
  - PCSO Surplus three complete dual band radios for our use
  
- ❖ With Yamhill County's growing population and expanding development, it is time to evaluate methods for guiding visitors into our communities and establishing an identity that makes our town a destination! An Open House was held at the West Valley Fire District on Monday, January 27<sup>th</sup> from 4 pm to 6 pm to see the new identity and wayfinding signs for Sheridan, Willamina, and Grand Ronde. A well-designed wayfinding system helps to unify a city and builds a sense of place where residents and visitors feel safe to explore. The three communities will share a unified look and feel, while allowing each community its own identity.
  
- ❖ GIS map:
  - Please find attached a map demonstrating current fire station locations and proposed fire station locations within the three districts.
  
- ❖ Pay Equity:
  - The Districts have entered into a contract with HR Answers to gain compliance with Oregon's Pay Equity law requiring an evaluation of position and position descriptions regarding their working conditions, responsibility, effort, skill and knowledge.
  - Staff anticipates this project to be accomplished within the next few months.
  
- ❖ Monthly Activity Report:
  - Please find attached the Monthly Activity Report for all three districts
  
- ❖ Fire Corps – Support Services
  - This program involves non-fire response activities; like the following:
    - Chaplains
    - Water Tender Drivers

- Photographers
  - Office Assistants
  - Firefighter Rehabilitation Personnel
  - EMS Personnel
  - Other
- ❖ First Annual Awards Banquet:
- Awards given:
    - 2019 John Fancher Memorial Award, Fire- Jack DeJong
    - 2019 John Fancher Memorial Award, EMS- Christopher Hoopingarner
    - 2019 Firefighter of the Year- Hunter Michaelson and Lionel Schmidt
    - 2019 EMS of the Year- Brandon Trombla
    - 2019 Dedication of Service- Robert Foster and Chilano Randall
    - 2019 Officer of the Year- Brad Weaver
    - 5 Years of Service- Cody Coonrod and Tricia Young
    - 10 Years of Service- Tony Maca
    - 15 Years of Service- Donna Hammer
    - 35 Years of Service- Brendan Herber
  - Dallas Fire & EMS and McMinnville Fire Departments provided coverage during our awards banquet. We will be repaying this coverage during their respective banquets.

# Sheridan, SW Polk and West Valley Fire Districts

## JANUARY 2020 MONTHLY REPORT

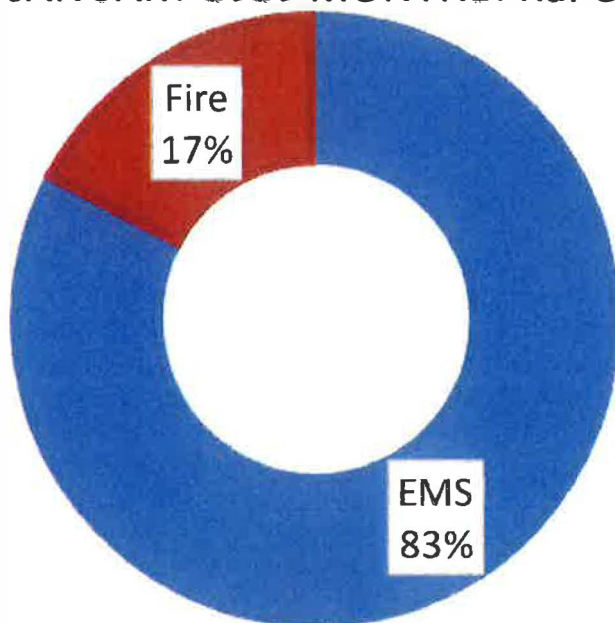

### Fire Stats

Structure fire-	4
Natural vegetation fire-	1
Electrical-	2
Controlled burning-	1
Fire alarm-	1
Spills & leaks-	1
Smoke, odor problem-	1
Public service assistance-	1
Unauthorized burning-	2
Call cancelled-	18
Accident-	1
<b>Total</b>	<b>40</b>

### EMS Stats

Public assist-	5
Unit assist-	5
Call cancelled-	18
Patient dead on scene-	2
Not transported-	41
Transported-	112
Medical assist-	2
MVA-	5
<b>Total</b>	<b>190</b>

**Total Calls 230**

**Training Hours 885.830**

# Sheridan Fire District

## JANUARY 2020 MONTHLY REPORT

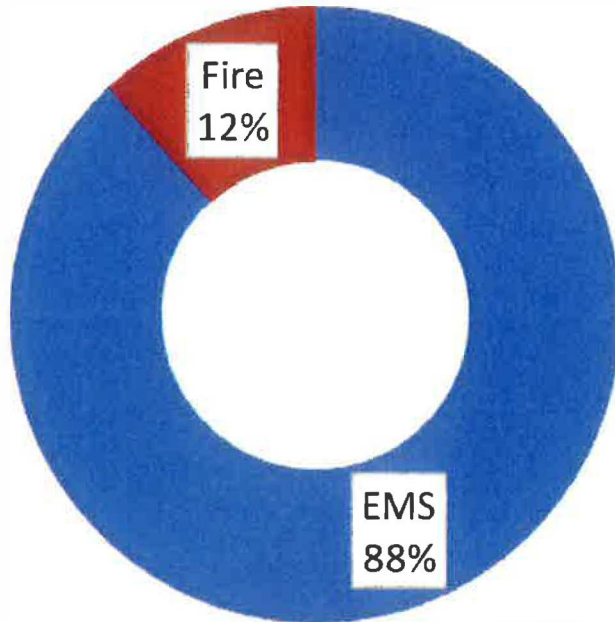

### Fire Stats

Structure fire-	2
Spills & leaks-	1
Smoke, odor problem-	1
Public service assistance-	1
Unauthorized burning-	1
Call cancelled-	6
<b>Total</b>	<b>12</b>

### EMS Stats

Public assist-	2
Unit assist-	3
Call cancelled-	8
Patient dead on scene-	1
Not transported-	15
Transported-	61
<b>Total</b>	<b>90</b>

**Total Calls 102**

**Training Hours 494.33**

# SW Polk Fire District

## JANUARY 2020 MONTHLY REPORT

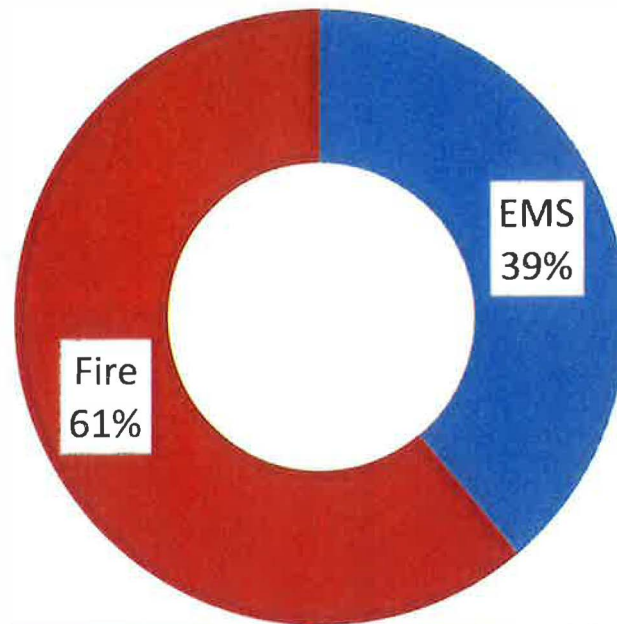

### Fire Stats

Structure Fire-	2
Natural vegetation fire-	1
Electrical-	1
Call cancelled-	5
Controlled burning-	1
Fire alarm-	1
<b>Total</b>	<b>11</b>

### EMS Stats

Medical assist-	2
Motor Vehicle Accidents-	5
<b>Total</b>	<b>7</b>

**Total Calls 18**

**Training Hours 61.5**

# West Valley Fire District

## JANUARY 2020 MONTHLY REPORT

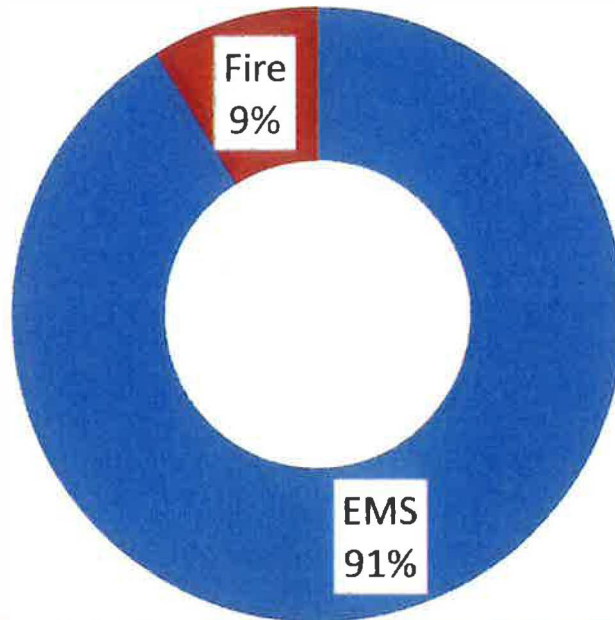

### Fire Stats

Electrical-	1
Unauthorized burning-	1
Call cancelled-	7

**Total** 9

### EMS Stats

Public assist-	3
Unit assist-	2
Call cancelled-	10
Patient dead on scene-	1
Not transported -	26
Transported lights/siren-	51

**Total** 93

**Total Calls** 102

**Training Hours** 330